

## SHERLINE Live Center

P/N 1191

---

### Use of the Live Center

The Sherline lathe comes equipped with two dead centers. One has a #1 Morse taper and fits the headstock. The other has a #0 Morse taper and fits into the tailstock. These centers are used for holding parts that are mounted "between centers". This system of mounting work in a lathe has been in use for many years. However, since the tailstock center is held stationary and does not turn with the part, it is a point of friction and requires frequent oiling and attention. Also, because of thermal expansion caused by friction generated heat, the pressure of the tailstock center must be checked frequently. This is especially important for parts made of thermal plastic materials, which tend to soften and even melt as a result of heat.

The Sherline live center is designed to eliminate these problems. The center is ball bearing mounted so that it can rotate with the part. This reduces wear and heat and makes machining much more pleasant. The sealed bearings are permanently lubricated and require no maintenance. If you plan to do much turning between centers on your lathe, a live center would be a useful accessory to have in your toolbox.

For items with a large center hole or for tubing, a [bullnose live center \(P/N 1182\)](#) is available.

EXPLODED VIEW AND PART NUMBERS

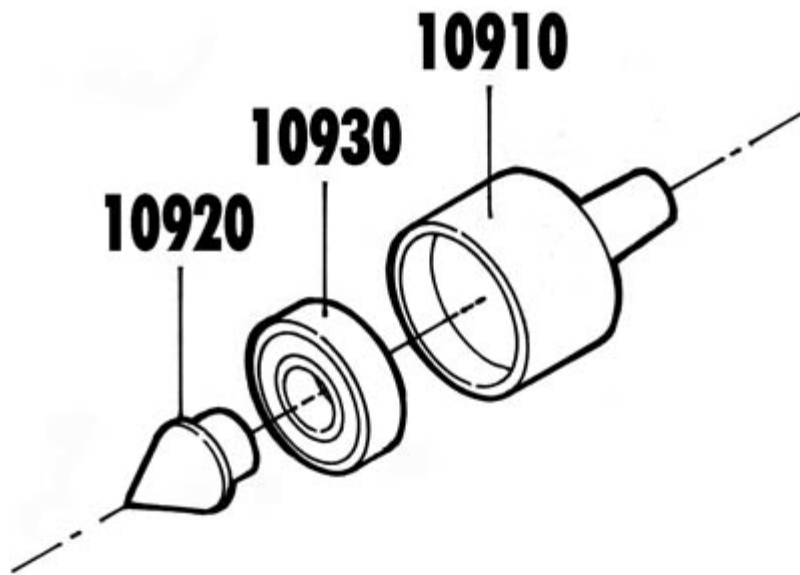

Note: The bearing and nose piece are pressed in at the factory. Once assembled, the 1191 Live Center is not considered user-serviceable. Parts are shown for reference only.