

**SHERLINE
PRODUCTS**

INCORPORATED 1974

ROTARY COLUMN ATTACHMENT

P/N 3500

Angle drilling on a standard 3-axis mill

Full-size milling machines have the spindle mounted in a “quill” which advances the cutting tool from the headstock. This allows a hole to be drilled on an angle because the quill can be used to move the spindle in and out to drill a hole while the headstock is angled to the side. The Sherline mill has a headstock that can be rotated to do angle milling, but without a quill to move the spindle in and out, angle drilling cannot be accomplished unless the part is mounted perpendicular to the headstock so that the Z-axis handwheel can be used to advance the headstock. The rotary column attachment allows parts to be mounted square to the table yet still be drilled at an angle by allowing the entire column to be rotated to any desired angle. In this way the Z-axis handwheel now advances the headstock at the desired angle so that angled holes can be drilled.

Installing the rotary column attachment to open up more milling and drilling possibilities

The attachment is easy to install. You start by removing the headstock from the column saddle. Now remove the 4 socket head cap screws that hold the column bed to the column base. Next put the graduated clamping ring on the fixed clamp plate. Bolt the fixed clamp plate and graduated ring assembly to the 4 holes in the column base. The moveable clamp ring is then bolted to the vertical column bed. (Note the direction of the non-symmetrical hole pattern.) The column bed can now be mounted to the column base using the four cap screws that go through the movable clamp ring into the tapped holes in the graduated clamp ring. Tighten these screws carefully so the ring is pulled up squarely.

Mount the headstock to the column saddle and align it carefully using the alignment key. Use a dial indicator to square the column to the table (see page 16 in the *Assembly and Instruction Guide, 6th Ed.*), and lock it in place with the clamping screws. The magnified scribe and mounting block can then be glued to the top of the column base at the “zero” location. Most any type of glue or epoxy will work well, but the mating surfaces must be clean.

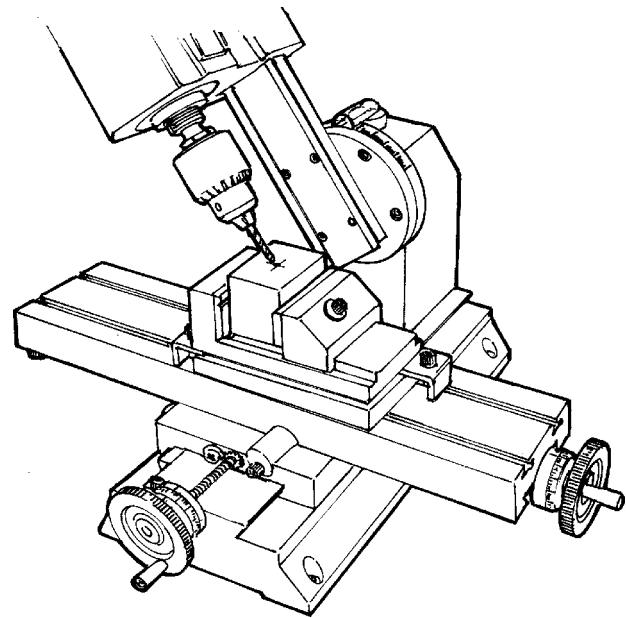

FIGURE 1—Tilting the Z-axis column makes drilling a 30° angled hole easy. The calibrated adjustment ring and magnifying sight on the “zero” scribe line make setting an angle easy and quite accurate. The column can be rotated up to 90° in either direction.

Why “pinning” the column is not recommended

I don’t recommend “pinning” the column in the vertical position with a dowel pin. This arrangement can cause more problems than it eliminates. When a dowel pin fits the hole tightly enough to be considered accurate, the dowel pin is very difficult to remove. If it’s loose enough to be easily removed, it is not accurate enough to do you much good. Most full size milling machines do not use any pinning methods to square up their heads because it is just not accurate enough. “Indicate in” your head each time it is returned to the vertical position to be sure it is perpendicular to the mill table.

Joe Martin, President and Owner
Sherline Products Inc.

Lowering the column

Note that the hole pattern in the moveable clamp ring (ref. #3 in drawing below) is not symmetrical. Mounting the column with the plate as shown will give you the maximum clearance under the spindle. If you are using collets or for some other reason need to get the spindle as close to the table as possible, this ring can be rotated 180° to get the hole pattern closer to the bottom, which will lower the column. Doing this

might require that the leadscrew be shortened about 1/2" so that it does not hit the top of the ring. If sawing off the leadscrew, leave the saddle nut in place so that you don't have to thread it back on over the cut threads at the end of the leadscrew. Place the leadscrew in a vise holding it by the end that will be cut off. Use a hacksaw to remove the excess length. Clean up and bevel the cut threads slightly with a file.

EXPLODED VIEW

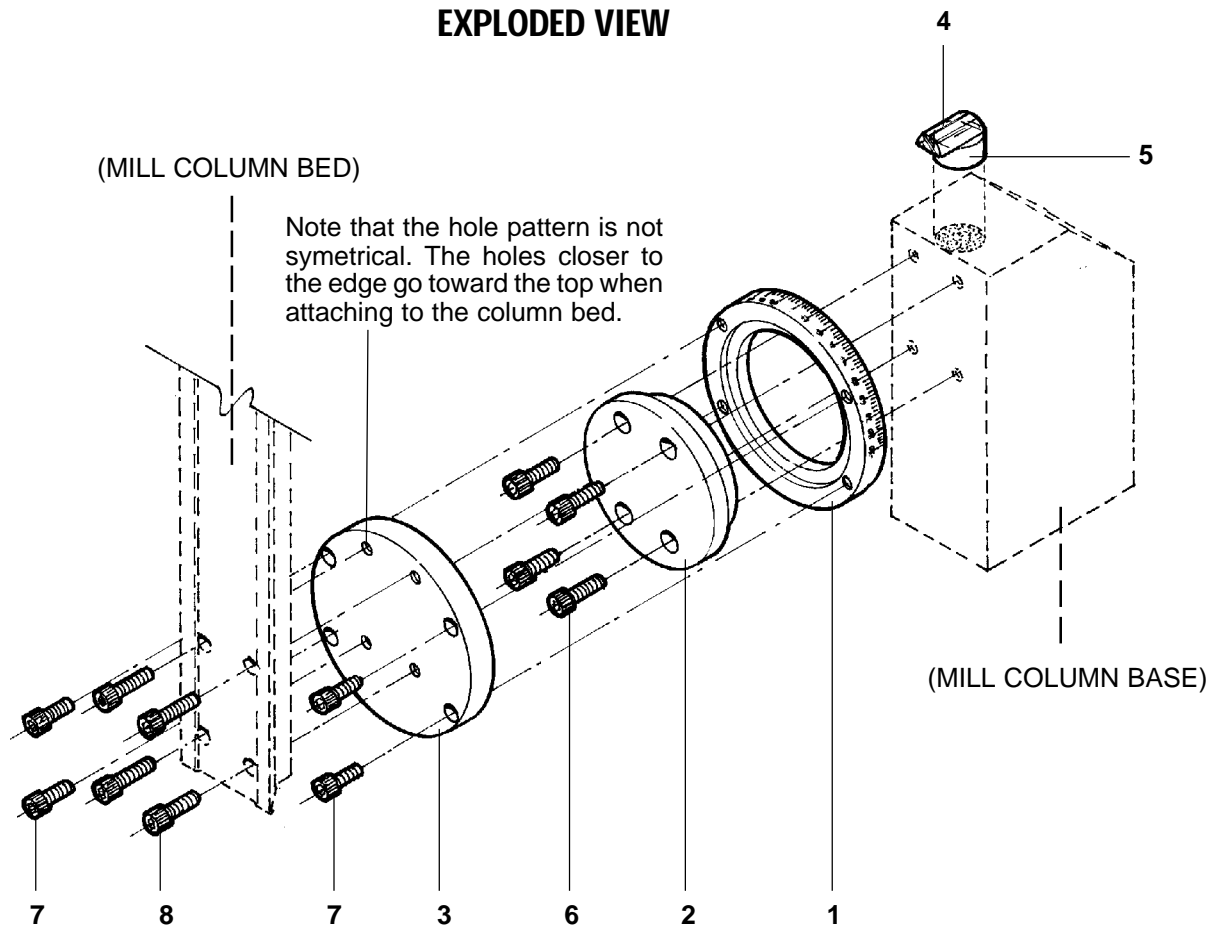

PARTS LISTING—P/N 3500

REF NO.	P/N	NO. REQ.	DESCRIPTION
1	3516	1	Graduated Clamping Ring
2	3515	1	Fixed Plate
3	3517	1	Moveable Clamp Ring
4	3518	1	Magnified Scribe Lens
5	3519	1	Scribe Lens Mounting Block
6	4033	4	10-32 x 5/8" Skt Hd Cap Screws
7	4067	4	10-32 x 1/2" Skt Hd Cap Screws
8	4069	4	10-32 x 3/4" Skt Hd Cap Screws