

SHERLINE
PRODUCTS
INCORPORATED 1974

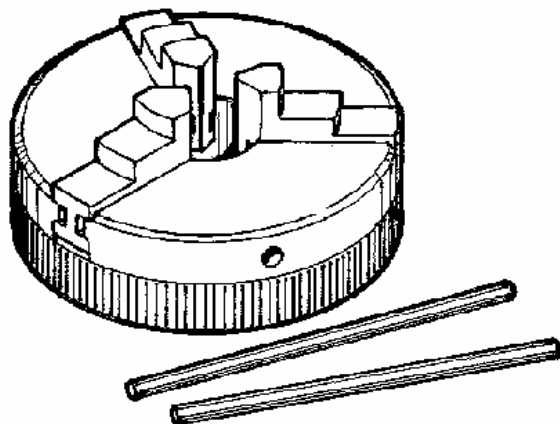

SHERLINE 3-Jaw Self Centering Chucks

P/N 1040 3-Jaw Chuck, 3.125" Diameter

P/N 1041 3-Jaw Chuck, 2.5" Diameter

CAUTION! DO NOT OVERTIGHTEN CHUCK. Use only moderate pressure with the Tommy Bars supplied.

IMPORTANT! DO NOT TURN THE LATHE SPINDLE ON UNLESS THE CHUCK IS TIGHTENED. Acceleration of the spindle can cause the scroll to open the chuck jaws if they are not tightened!

NOTE: To prevent permanent damage to the chuck, finished, turned or drawn stock only should be held with this chuck. For rough castings, etc., use the 4-jaw chuck.

Always wear your safety glasses when operating metalworking equipment.

Instructions for Use

Three-jaw chucks are designed so that all three jaws move together and automatically center round or hexagonal parts or stock to within a few thousandths of an inch. These chucks provide the quickest and easiest way of holding work in the lathe. Unlike drill chucks, you do not need a geared "key" to open or close them. To tighten or loosen the chuck, simply turn the outer ring with one hand while holding the knurled inner ring in your other hand. Spindle bars, sometimes called "Tommy" bars, are provided and can be used in the holes in each ring to apply more leverage to tighten or loosen the chuck.

The Sherline chuck is designed so that it can be used to clamp externally on bar stock or internally on tube stock. The P/N 1041 chuck is designed to grip from 3/32" (2mm) to 1-3/16" (30mm) diameter stock with the jaws in the normal position. The P/N 1040 chuck handles stock up to 1-1/2" (38mm) in diameter. For larger diameter work, the jaws must be reversed (See Figure 2). The reversible jaws can grip to 2-1/4" (56.0 mm) for the P/N 1041 chuck and up to 2.75" (70 mm) for the P/N 1040 chuck. The chucks have a .687" (17mm) diameter through hole with a 3/4"-16 thread.

Due to the nature of the design of a 3-jaw chuck, it cannot be expected to run perfectly true. Even 3-jaw chucks costing five times more than the one made for this lathe will have a 0.002" to 0.003" runout. If perfect accuracy is desired in a particular operation, the use of a 4-jaw chuck or a collet is recommended. Both are available for your Sherline Lathe.

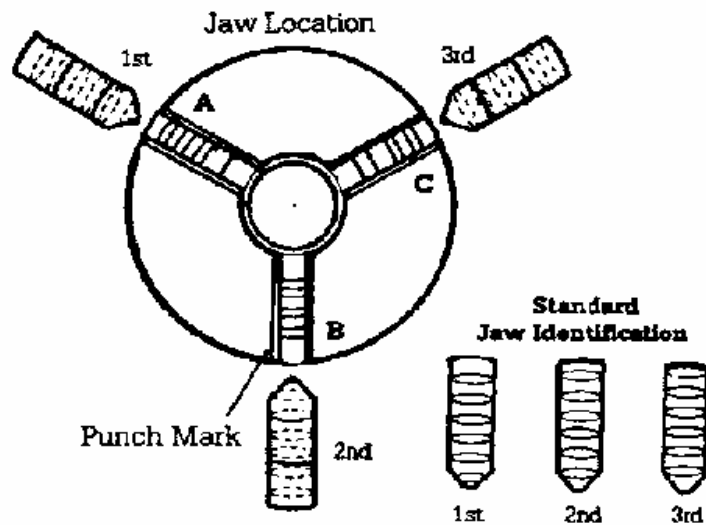

FIGURE 1—Three-Jaw Chuck, standard jaw locations.

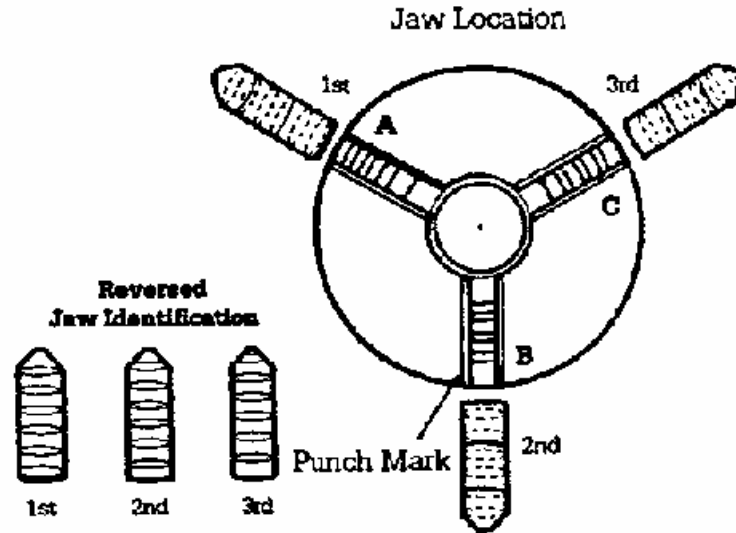

FIGURE 2—Reversing the Chuck Jaws.

NOTE: Always start with position "A". To reverse the chuck jaws, rotate the knurled scroll until the jaws can be removed. They can be easily identified by the location of the teeth to the end of the jaw (See Figures 1 and 2). To maintain chuck accuracy, the 2nd jaw must always be inserted in the same slot even when the jaws are reversed. This slot is identified by a punch mark next to the slot. Always insert the jaws in the order and location shown on the drawings. Turn the scroll counter-clockwise when viewed from the face of the chuck until the outside start of the scroll thread is just ready to pass the slot for the 1st jaw. Slide the 1st jaw as far as possible into the slot. Turn the scroll until the 1st jaw is engaged.

Due to the close tolerances between the slot and jaw, the most difficult part of replacing the jaws is engaging the scroll thread and 1st jaw tooth without binding. Therefore, never use force when replacing the jaws, and if binding occurs, back up the scroll slightly and wiggle the jaw until it is free to move in the slot. Advance the scroll and repeat for the 2nd and 3rd jaws. The scroll thread must engage the first tooth in the 1st, 2nd and 3rd jaws in order.

A set of replacement jaws, P/N 1141 is available. Should it become necessary, please return your chuck to the factory so that we may replace the jaws and check the alignment before returning it to you. In the case of a damaged chuck body, replacement of the entire chuck is usually more economical than attempting repairs

Removing a chuck from the spindle

Use one tommy bar in the hole in the spindle and another tommy bar in a hole in the rear ring of the chuck body to achieve enough leverage to unscrew the chuck (counterclockwise) from the spindle thread. If the chuck becomes stuck on the spindle thread, put a tommy bar in the hole in the chuck body. Place a block of wood against the tommy bar where it enters the chuck. With a small mallet, give the block of wood a sharp tap, turning the chuck in a counter-clockwise direction. It should not be necessary to hold the spindle, as its inertia should be sufficient. (Don't

hit the tommy bar anywhere other than right where it enters the chuck or you could bend it.) This small but sharp force at the outer edge of the chuck should break the thread loose and the chuck can then be unscrewed by hand or with the tommy bars. .

Lubrication and maintenance

Clean chips from the jaw slots with a brush and add lubrication periodically to keep the chuck operating smoothly. To prevent rust, keep the surfaces of the chuck lightly oiled. If possible, store wrapped in the waxed paper it came in.