

SHERLINE PRODUCTS

INCORPORATED 1974

COLLET FIXTURE

P/N 1164 (for Sherline WW Collets .312-.313 dia.)
P/N 1165 (for 8 mm Collets .314-.315 dia.)

This holder is manufactured in two different sizes. The 8 mm holder (P/N 1165) takes collets made by other manufacturers that measure 0.314" to 0.315" O.D. Sherline WW collets measure 0.312" to 0.313" and use the P/N 1164 holder. If you use non-Sherline collets, be sure to check their size before ordering this fixture. The 8 mm holder is identified by the slight V-groove machined around the cylinder of the holder. The WW holder has no groove.

Development of the Sherline collet fixture

The WW collet holder was brought into being because of a request by David Lindow, a clockmaker from Pennsylvania who wanted to use WW collets with his CNC rotary table. I came up with this particular design because it could also be mounted to our standard milling table. This would allow clockmakers and watchmakers to use all the neat tooling they have developed over the years with Sherline machines. Of course, it hasn't been designed with only this group in mind, and we hope that this will be a useful accessory for many others as well.

Using the collet fixture

A WW or 8 mm collet (depending on model) is inserted into the center hole from the top, making sure to align the collet with the drive pin inside to avoid damaging the collet threads. The pin is held in place with LocTite® and can be adjusted or removed if necessary. A thread in the center of the knurled ring engages the collet and pulls it down into the taper to close the collet on the part when the ring is rotated in a counterclockwise direction. To release the collet, simply rotate the ring clockwise.

Centering the collet fixture on a rotary table

It would be just about impossible to manufacture a product such as this that wouldn't require the use of an indicator to accurately mount the holder on the rotary table. I believe that any fixture that is mounted should always be mounted with the highest possible degree of accuracy, and any error is too much. You might use the same setup at a later date on a job that requires total accuracy while forgetting you did a poor setup job, and the part will be ruined. To make the job easier, use the included bushing to locate the holder within a few thousandths of an inch (0.01 mm) of the center of the rotary table. (See Figure 1.) Mount the holder to the rotary table with the hold-down screws tightened just enough so the holder can still be moved with a light tap from a plastic mallet. Now use a dial indicator to bring the holder to its final position by reading the runout error as the table is rotated. After all runout is eliminated, give the hold-down screws a final tightening.

Mounting the fixture to a mill table

The holder can also be mounted to any milling table. When the holder is mounted to a Sherline mill, the base of the holder should be mounted with one mounting screw in each T-slot. It will be

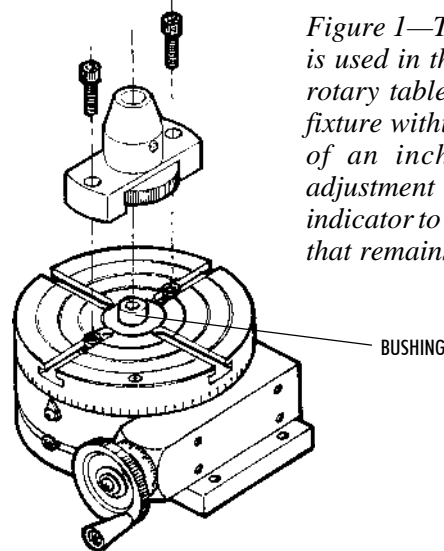

Figure 1—The included bushing is used in the center hole of the rotary table to locate the collet fixture within a few thousandths of an inch of center. Final adjustment is done using a dial indicator to eliminate any runout that remains.

necessary to mount it at an angle across the two T-slots to accommodate the difference between the centerline of the T-slots and hold-down screws.

Drilling a center hole through your rotary table

The center hole in the rotary table is already 1.1" (28 mm) deep. This allows long parts to extend past the bottom of the collet fixture. If you need even more clearance, the hole in the center of the Sherline rotary table can be drilled all the way through the table to hold longer parts if needed. The maximum hole size could be up to 1/2" (13 mm), but if the diameter is kept to 1/4" (6 mm) or less, it will not eliminate the threads that allow you to mount a chuck to table using the screw-in chuck adapter. It will also retain the use of the centering bushing to align the collet fixture. The table isn't hardened and can be easily drilled through on a drill press. We choose not to drill this hole through in production to help seal the bottom of the rotary table from the debris and cutting oils that can accumulate during machining.

—Joe Martin, President and Owner
Sherline Products Inc.

PARTS LIST

P/N	DESCRIPTION
11641	WW collet fixture body (P/N 1164 only)
11642	Collet fixture nut
11643	Collet fixture alignment bushing
11644	8-32 Drive pin
11651	8 mm collet fixture body (P/N 1165 only)
30561	10-32 T-Nuts (2)
40670	10-32 x 1/2" SHCS (2)