

**SHERLINE**  
**PRODUCTS**  
INCORPORATED 1974

## **KNURLING TOOL AND HOLDER**

**P/N 3004**

The knurling holder manufactured by Sherline is designed to be used only with the Sherline lathe. The largest diameter that can be knurled is 1" (25.4mm) and the smallest diameter is somewhat dependent on the pitch on the knurl. The higher the number of teeth per inch (TPI) the finer the knurl will be and the smaller the diameter that can be knurled.

Included with your holder is a set of basic knurls (25 TPI) that produce a medium diamond knurled pattern. This set is a left and right pair with a 30° helix with each tool forming half of the diamond pattern.

A good knurl is produced by embossing; therefore, a correct starting diameter on the work to be knurled can best be determined by trial and error on a scrap piece of similar material. When knurls are forming they should be considered similar to one gear meshing with another. Think what would happen if you tried to mesh a 25-tooth gear with a gear that had 62-1/2 teeth. This is in effect what happens if the initial diameter is wrong causing the tools to take a second path every other revolution. This produces an undesirable finish.

The good part is that knurls have an amazing tolerance for wrong diameters when working with soft materials, and you will have better than an 70% chance of success on any given diameter.

Hard materials such as stainless and hardened tool steels will have short tool (knurls) life. Never attempt to knurl hardened material, such as piano wire.

The knurling holder is designed to mount directly to the crossslide's tee slot groove. The tee nuts that run in the groove should only be tightened enough to eliminate "play", but not so tight as to keep the holder from moving freely in the groove. This allows the holder to self center on the part to be knurled. (We recommend using aluminum for your first practice knurl, approximately 1/2").

The part to be knurled or experimental part should be running true with a chamfered corner at the end of the knurled section. Adjust the top and bottom clamping bolts so the knurls are lightly touching the part without

the spindle turning. The knurls should be located at the beginning of the section to be knurled. Apply a liberal amount of cutting oil to the knurls and have the spindle run at a slow speed (approximately 500 RPM for 1/2" diameter of soft material). Now start tightening the top and bottom clamping bolts evenly, one at a time until the knurls are engaged with the work in a positive manner. Back the knurls off the part with the feed handwheel. Stop the spindle and carefully examine the quality of the knurl. It should be full depth, clean, and sharp. The finished diameter should be larger than the starting diameter by approximately the amount shown in the chart on the next page. If not make the necessary adjustments.

If the knurl isn't full depth take in on clamping bolts with the spindle running until it is full depth. (If the knurls are undercutting the finished diameter, the diameter should be either increased or decreased by approximately .005" (.1mm) until the knurls are working properly.) Increasing the diameter will add a tooth to the part. Decreasing the diameter will eliminate the knurls from having to remove so much material. If the knurl isn't clean and sharp use more cutting oil and turn the spindle slower and increase the feed.

As you can see it isn't an exact science because of the many variables involved and that is why we recommend getting good results on a scrap part before attempting knurling a part you have a lot of work in.

Straight knurls have to be more carefully selected for the job if they are to be used for enlarging a shaft diameter for a press fit. In closer tolerance production work special knurls have to be made to accomplish this so the finer the knurl the better your chances of success are.

To complete the knurl the knurls are fed on to the part for the proper distance using plenty of cutting oil. Back the knurls off the part still using plenty of oil and you should have a knurl you can be proud of.

Joe Martin, President and Owner  
Sherline Products Inc.

## EXPLODED VIEW

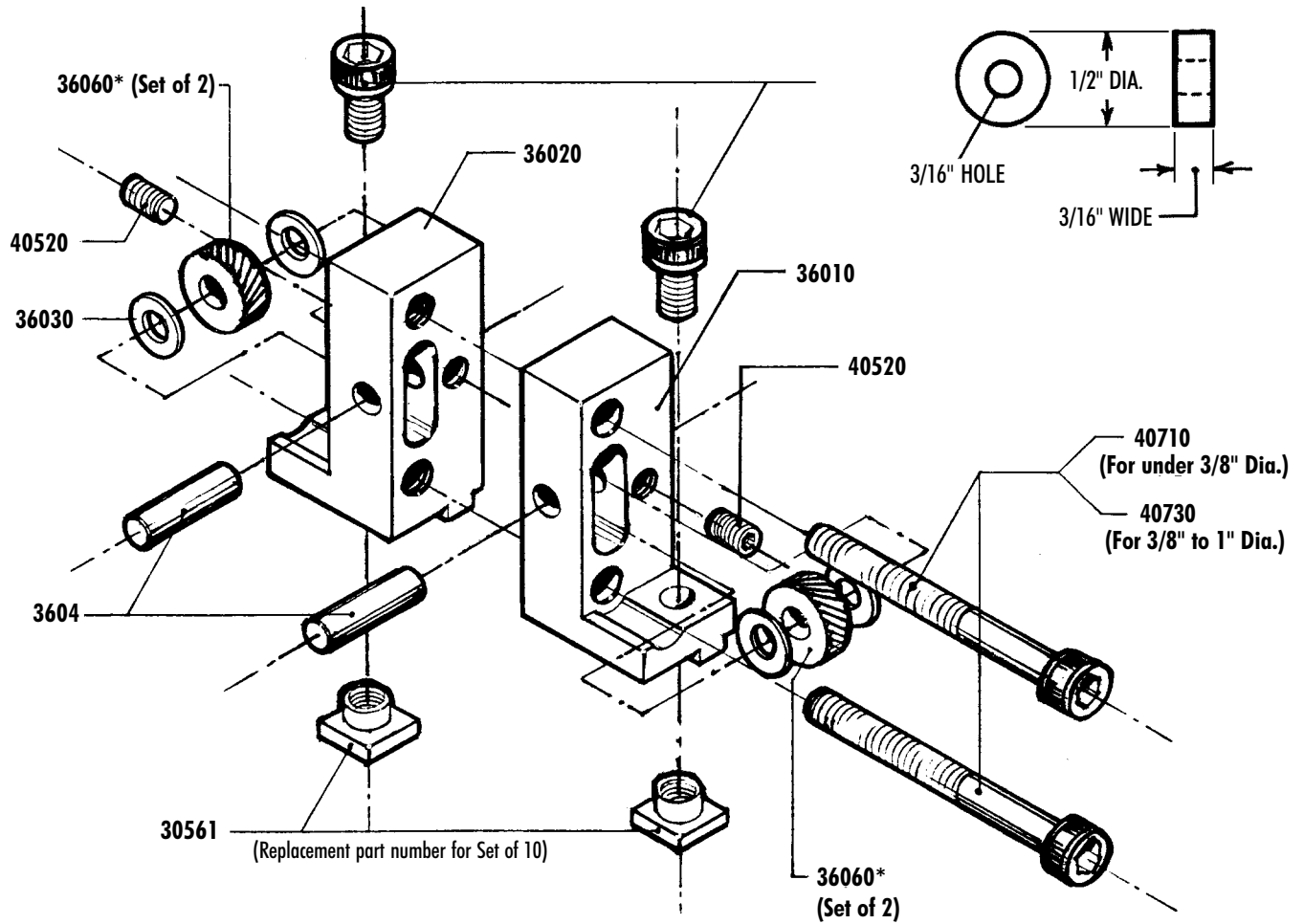

## OPTIONAL CIRCULAR PITCH KNURLS

TPI=Threads Per Inch/T=Teeth on the knurl

**36060\*** (Std. Set of 2)  
21 other patterns available,  
see charts below.

STRAIGHT TOOTH KNURLS			
PART NUMBER	TOOTH ANGLE	TPI / T	QTY
3612	90°	16 TPI / 25T	PR.
3613	90°	20 TPI / 31T	PR.
3614	90°	25 TPI / 38T	PR.
3615	90°	30 TPI / 47T	PR.
3616	90°	32 TPI / 49T	PR.
3617	90°	35 TPI / 55T	PR.
3618	90°	40 TPI / 63T	PR.
3619	90°	41 TPI / 65T	PR.
3620	90°	47 TPI / 73T	PR.
3621	70°	35 TPI / 55T	PR.
3622	70°	50 TPI / 79T	PR.
3623	70°	53 TPI / 83T	PR.
3624	70°	60 TPI / 94T	PR.
3625	70°	60 TPI / 109T	PR.
3626	70°	80 TPI / 125T	PR.

30° SPIRAL KNURLS			
PART NUMBER	TOOTH ANGLE	TPI / T	QTY
3605	90°	20 TPI / 27T	PR.**
3606*	90°	25 TPI / 34T	PR.**
3607	90°	30 TPI / 40T	PR.**
3608	90°	35 TPI / 47T	PR.**
3609	90°	40 TPI / 55T	PR.**
3610	70°	50 TPI / 68T	PR.**
3611	70°	80 TPI / 107T	PR.**

\*INCLUDED AS STANDARD WITH TOOL.  
\*\*PAIR INCLUDES ONE LEFT HAND AND ONE  
RIGHT HAND KNURL USED TOGETHER TO  
MAKE A DIAMOND PATTERN.

APPROXIMATE INCREASE IN KNURLED DIAMETERS					
TPI	TOOTH ANGLE	STRAIGHT	DIAGONAL	DIAMOND	
				MALE	FEMALE
12	90°	.034	.034	.038	—
16	90°	.025	.025	.029	—
20	90°	.020	.020	.023	.014
25	90°	.016	.016	.018	.011
30	90°	.013	.013	.015	.009
35	90°	.011	.011	.013	—
40	90°	.009	.009	.010	.006
35	70°	.014	—	—	—
40	70°	.012	.010	—	—
50	70°	.009	.009	.010	.006
60	70°	.007	.007	—	—
70	70°	.006	.006	—	—
80	70°	.005	.005	—	—