

Right Hand Cutting Tool

Left Hand Cutting Tool

Boring Tool

SHERLINE PRODUCTS

INCORPORATED 1974

GRINDING YOUR OWN LATHE TOOLS

NOTE: As with any machining operation, grinding requires the utmost attention to "Eye Protection". Be sure to use it when attempting the following instructions.

My first experience in metal cutting was in high school. The teacher gave us a 1/4" square tool blank and then showed us how to make a right hand cutting tool bit out of it in a couple of minutes. I watched closely, made mine in ten minutes or so, and went on to learn enough in one year to always make what I needed. I wasn't the best in the class, just a little above average, but it seemed the below average students were still grinding on a tool bit three months into the course. I believe these students didn't have the confidence in themselves to work with their hands. Grinding lathe tools is easy, and the only reason we sell them is to help a beginner get started. If you are to be successful in making metal parts on a lathe, you have to teach yourself to grind tool bits.

Consider a carpenter who didn't have the confidence to drive a nail because he was worried about missing the nail and hitting his thumb. He/she wouldn't be in the trade very long! Some things you do in trades require a positive approach and tool grinding is one of them. If you keep stopping to see if you're grinding it correctly you'll not only waste a lot of time, but will end up with a less than perfect cutting edge. Set up the grinder correctly and do it! It shouldn't take but a few minutes to make simple cutting tools and only a few seconds to resharpen them.

A bench grinder doesn't have to be expensive to work well, but it does require good "wheels" for high speed steels. Try to find a source for grinding wheels from an industrial supplier. Some of the wheels that come with inexpensive grinders wouldn't sharpen a butter knife. Sixty grit is a good place to start. A wheel dresser is also a necessity. They cost less than \$10 and are readily available from good hardware stores.

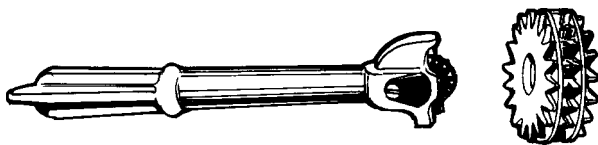

FIGURE 1—A wheel dressing tool and spare "star wheel" sharpening insert.

Grinding wheels should be considered cutting tools and have to be sharpened. A wheel dresser sharpens by "breaking off" the outer layer of abrasive grit from the wheel with star shaped rotating cutters which also have to be replaced from time to time. This leaves the cutting edges of the grit sharp and clean.

A sharp wheel will cut quickly with a "hissing" sound and with very little heat by comparison to a dull wheel. A dull wheel produces a "rapping" sound created by a "loaded up" area on the cutting surface. In a way, you can compare what happens to grinding wheels to a piece of sandpaper that is being used to sand a painted surface; the paper loads up, stops cutting, and has to be replaced.

For safety, a bench grinder should be mounted to something heavy enough so it will not move while being used. The tool support must be used and should be set at approximately 7°. Few people have the skill to make tools without a tool support and in essence it's wasted effort. Tool supports are usually made up of two pieces that allow you to set your tool rest above or below center. It really doesn't matter whether its above or below as long as the support is at 7°.

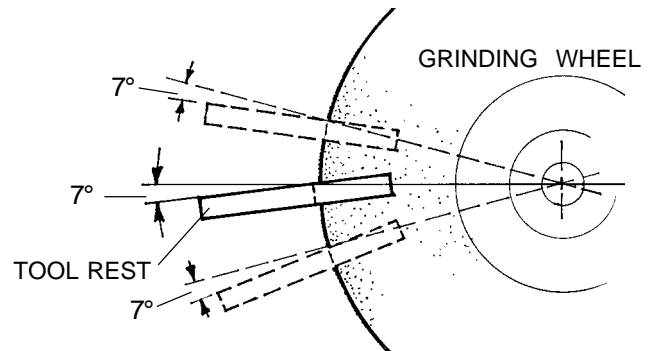

FIGURE 2—Set tool rest at any height, but at 7° angle from centerline of wheel.

The reason tool supports are designed like this is so they can be used for a variety of uses, not just tool bits. What this means is that if the tool support is above or below center it must be adjusted as the wheel diameter changes.

Now it's time to make a tool, and whether you turn this job into a major project is up to you!

When working around grinders it is an absolute necessity to wear EYE PROTECTION. Grinding debris is thrown out at high velocities and can damage not only eyes, but also expensive glasses. Wear safety glasses or a full face shield.

If you've never sharpened a tool, take a close look at how ours are sharpened. Let's duplicate the right hand tool on the opposite end of the blank. Be careful you don't cut yourself on the blank or the sharpened end while working with it.

First dress the wheel by taking the dresser and setting it on the tool support square with the wheel and while applying a light pressure move the dresser back and forth with the grinder running. Unless the wheel is in bad shape, it should be ready to use in a few passes.

Grinding side 1 of the tool

Turn off the grinder and set the tool support for approximately 7° if you haven't done it yet. If you're not good at guessing at angles use a presharpener Sherline tool to set the angle. Metal cutting tools are very tolerant on angles. I've always found wood cutting tools more difficult to sharpen. Too little angle and the "heel" of the tool will rub, too much angle will cause the tool to "dig in" and chatter.

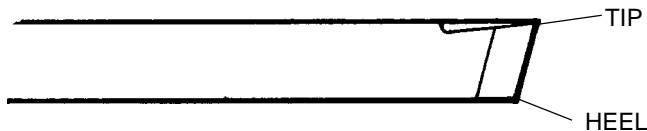

FIGURE 3—Heel of tool.

Have a cup of water handy to cool the tool with and set the blank on the tool rest and start grinding side 1.

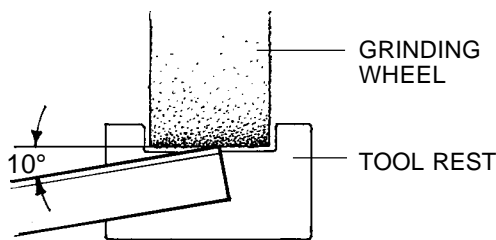

FIGURE 4—Grinding Side 1.

(NOTE: Because of 7° angle on tool rest, side of tool is actually cut first.)

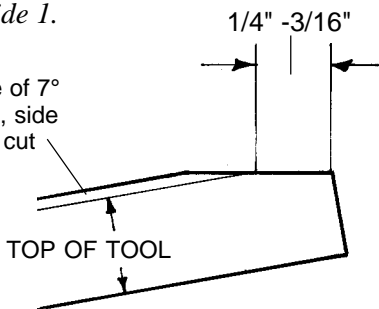

FIGURE 5—Properly ground side 1.

Move the blank back and forth across the face of the wheel until you have ground a 10° angle on approximately 3/16" (4mm) of side 1.

This is where the "positive approach" comes in. Unless you push the tool into the wheel with enough pressure, the tool will bounce around and you'll never get a good flat cutting

surface. It isn't necessary to worry about getting the tool too hot. Modern day tool steels don't anneal and a little discoloration doesn't effect the tool life in tool room use. What you should worry about is not burning yourself or grinding the tips of your fingers off! Concentrate on holding the 10° angle while moving back and forth. We'll give this edge a final sharpening later; it's time for side 2.

Grinding side 2 of the tool

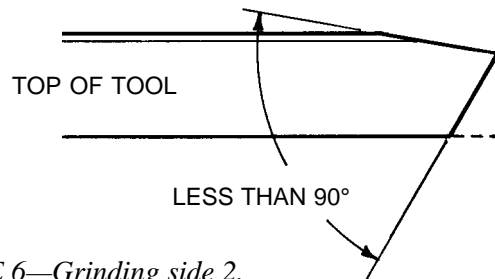

FIGURE 6—Grinding side 2.

The reason angle B is ground less than 90° is to allow the tool to get into corners.

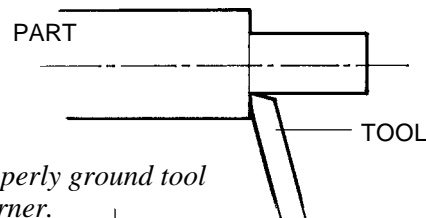
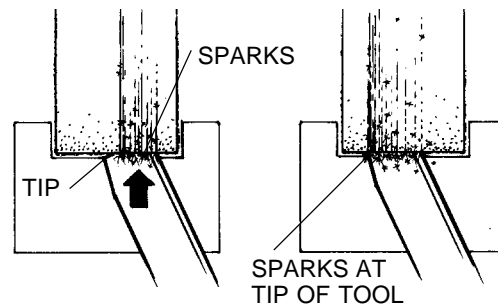

FIGURE 7—Properly ground tool cutting into a corner.

Side 2 is ground the same way as side 1, moving the tool back and forth until you have a point. After you get side 2 ground, cool the tool in the cup of water.

Now I want you to learn another aspect of tool grinding. It's important to know when you have ground the surface up to the cutting edge, especially when resharpening lathe tools. Take the tool you just ground and bring it up to the wheel at a slightly different angle than you just ground for this experiment. Watch the point that touches the wheel first and you will notice that the sparks will bounce off the cutting edge only where the wheel has ground from top to bottom.



FIGURES 8A—Tip not yet ground flat and 8B, Tool ground flat all the way to the tip.

This tells you when the tool has been sharpened without taking it away to look which allows you to grind flat and true surfaces. If you sharpen a tool for a Sherline lathe, use a 1/4" square tool blank and keep the cutting edge up to the top of the blank; the tool will come out on center without shims.

You will have to be precise grinding the third side to accomplish this.

Grinding side 3

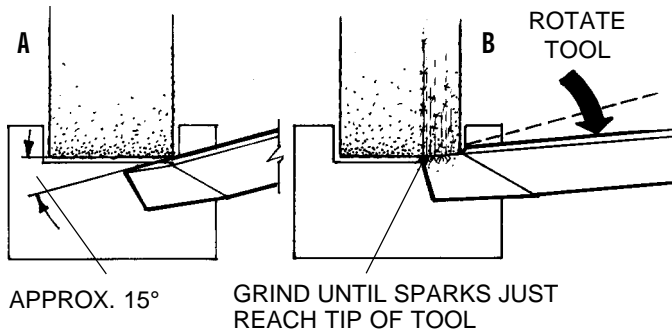
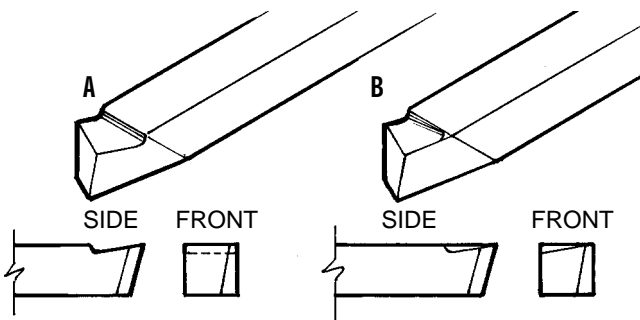

FIGURE 9—Grinding the "Hook" into side 3.

Use the skill you have developed grinding the second side now. Set the blank on the support with the 10° (side 1) up. The tool has to be brought up to the grinding wheel with a slight angle so you don't grind the tip below center. With the tool setting on the rest, move the tool in and grind until you see sparks bouncing off the cutting edge where the corner of the wheel is lined up with the back part of the 10° face. When this happens, slowly decrease the angle without pushing the tool in any more until sparks bounce all the way to the tip. Stop as soon as this happens. You may inspect it, and the surface should be entirely ground. The recommended way is to put more "hook" on the tool than I have suggested, but I have found that the slight increase in performance is offset by the problems encountered resharpening these tools.



FIGURES 10A—Normally recommended "hook" ground into tool and 10B, Simpler method suggested for Sherline tools.

To put the finishing touches on your tool, you have to "kiss off" sides 1 and 2 again. You must carefully line up side 1 with the wheel and bring it to the wheel in a positive manner with very little pressure; watch for the sparks on the cutting edge. What you're trying to accomplish is to make the tool set against the wheel on the same plane as when you first ground side 1. If the tool is held too rigid, it will not align itself, too loose and it will bounce around.

"Breaking" the point

Use the same method on side 2. The tool should be ready to use except for the point. I always put about a .010 (.2mm) "break" on the point by holding the tool with the point aimed

at the wheel face. Because two angles converge at the point, the angle in relation to the sides is greater. Think about it!

FIGURE 11—Putting a .010" "Break" on the tip of the tool.

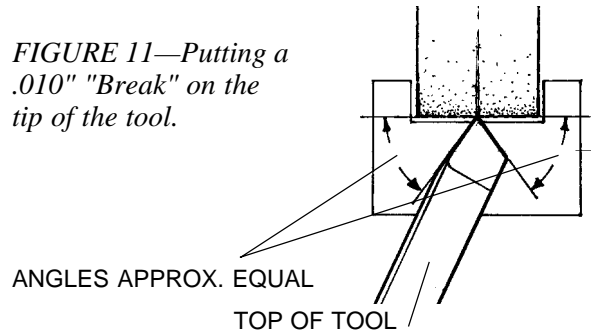

This means that if you set the tool flat on the tool rest the tool rest angle would have to be increased to get an even flat. This wouldn't be worth the effort, so the easy way is to free hand it. I always start by touching the heel of the tool first, and then change the angle until a slight flat is put on the tip. Of course, the angle you're holding it at has to be close when starting to get desired results.

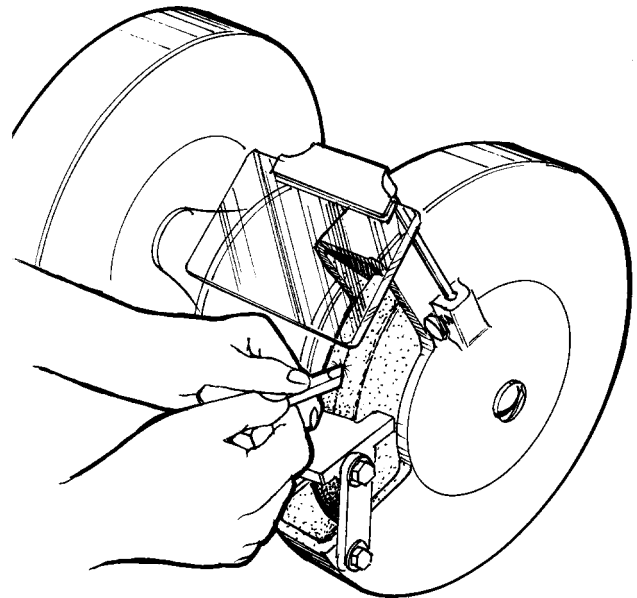

FIGURE 12—Handholding the tool to "Break" the point saves resetting the angle on the tool rest.

The purpose of this flat is to improve finish and tool life. I don't recommend a large radius on the tip of tools used on small machines. These machines are not rigid enough to get the desired results from this practice and cause "chatter" problems.

The finished product should be a right handed tool, have flat cutting surfaces (except for the radius caused by the wheel), have a slight flat on the tip, and a tip angle of less than 90°.

Tools used on lathes such as the Sherline will do all their cutting at the tip of the tool because they don't have the horsepower for 1/4" (6mm) cuts.

I don't recommend using oil stones to improve the edges. After a few minutes use with an occasional dab of cutting oil a properly sharpened tool will hone itself in.

I always believe the final sharpening to a tool should take place with the wheel cutting the cutting edge of the tool from the top of the tool to the bottom when using bench grinders.

I realize I've given a great deal of information on how to do what I call a simple operation, but these are very complex instructions to write because I'm trying to tell you how to control your hands, not a simple machine.

Incidentally, the reason we call a tool a right handed tool when the cutting edge is on the left is because it is designated by which way the chip leaves the cutting tool. Cutting tools such as left or right handed tin snips are also designated in this manner because the cut-off falls to the left or right.

The left hand tools are ground the same as right, in the same order with the angles reversed.

Boring tools

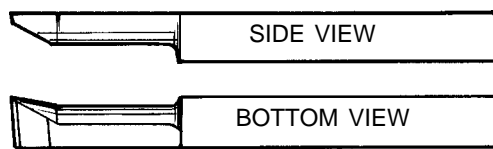
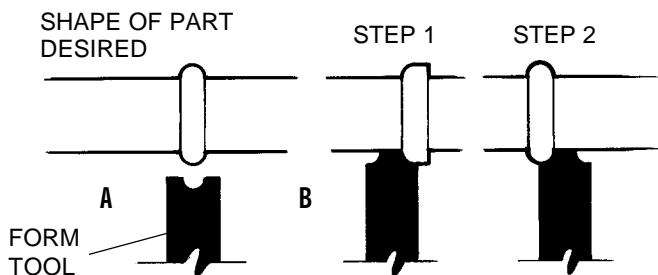

FIGURE 13--Typical boring tool.

Boring tools are the most difficult to grind. They should always be made as rigid as possible. Tool angles around the "tip" can be the same as any cutting tool, but clearances of the tool body have to be considered carefully. A tool ground with enough clearance for a finished hole may not have enough clearance to start with when the hole has a smaller diameter. If you have to bore a hole in a part that has a lot of work in it, have a tool ready to use that's been checked out on a piece of scrap.

Form tools

Form tools are used to create a shape the same as the tool. To grind form tools, a pattern of the finished shape should be at hand and there should be some possibility of success with what you have to work with. You can't grind a 1/8" (3mm) groove into your tool 1/4" (6mm) deep with a 1/2" (12mm) wide wheel.



FIGURES 14A—A typical form tool made by a custom toolmaking shop and 14B, a home shop method of achieving the same finished shape in two steps with a tool that can be ground on a bench grinder.

This type of tool is usually made by tool and cutter specialists that have high shop rates using precision grinders, diamond dressers, and a large variety of wheels available to them.

All is not lost if we have a good pair of hands with a good mind driving them! We can use the grinding wheel corners on our \$50 grinder and generate the shape 1/2 at a time on each side of the tool and still get our job done.

Form tools don't need any top relief (hook) to work. Use low spindle RPM and steady feed rates to prevent chatter. The width of a form tool should never exceed three times the smallest diameter of the finished part.

Like any skill, tool grinding is one that has to develop with time. It is also the skill that allows you to go one step beyond the average hacker.

Joe Martin, President and Owner
Sherline Products Inc.

High speed steel bits available from Sherline

PART NO.	DESCRIPTION
11950	H.S. STEEL CUTTING TOOL, RIGHT
11960	H.S. STEEL CUTTING TOOL, LEFT
11970	H.S. STEEL CUTTING TOOL, BORING
1200*	H.S. STEEL INTERNAL THREADING TOOL
3005	H.S. STEEL 1/4" SQUARE TOOL BLANK
3005B	H.S. STEEL TOOL BLANKS (5-BULK)
3007	H.S. STEEL SET (RIGHT, LEFT, BORING)

*NOTE, the Internal threading tool is very difficult to make on just a bench grinder. If a precision thread is required, I recommend you buy our P/N 1200, which is preground.