

**SHERLINE
PRODUCTS**
INCORPORATED 1974

NOTE: Separate instructions are available for P/N 3049 metric version.

BORING HEAD P/N 3054 (P/N 3049 Metric)

Boring holes on a mill is very similar to boring holes on a lathe except the cutting tool moves rather than the part. The main advantage of boring over drilling is that the hole will always come out in perfect alignment with the spindle whereas a drill may “wander”. Larger holes must be bored rather than drilled on a small mill because large drills cannot be held in a Sherline drill chuck, and it takes horsepower to drill holes over 3/8" (10mm).

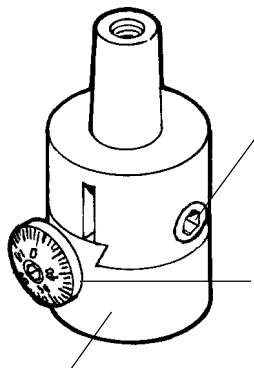

FIGURE 1

10-32 CAP SCREW—Tighten enough to hold in place while boring but loose enough to move bottom slide with 4-40 screw dial.

4-40 CAP SCREW DIAL—Tighten to increase diameter. To reduce diameter, loosen 10-32 and 4-40 screws and slide back.

Index bottom slide 180° for boring small diameter holes. (See also Fig. 2.)

Tools put in the Sherline boring head should be as short as possible to keep setups as rigid as possible. It is easier to bore a hole completely through a part than to cut into a flat bottom hole. The problem is tool chatter when you get to the bottom. A hole has to be started with a drill to the full depth of the finished hole. Many times the work will require a special boring tool that usually can be made from a standard boring tool.

Boring tools that are commercially available with a 3/8" shank have a shank that is too long for our boring head. To insure a rigid setup, cut part of the shank off. The shank of the tool should not extend much below the boring head. Sherline boring tools are ready to use without this cutoff operation.

Boring holes over an inch deep can get difficult because it takes long tools which compromises rigidity. If you need a large flat bottom hole, consider doing it on a rotary table with an end mill.

If you require a flat bottom hole, a good tip is to turn the spindle off .002" (.05mm) from the bottom and rotate the spindle by hand while feeding the spindle down the remaining distance to eliminate chatter at the bottom. A wrench on the boring head drawbolt can make it easy to rotate while cutting.

If you have an existing hole's location out of tolerance, many times you can use a boring tool to correct the location. A boring tool follows the spindle, not the hole. A bushing can be made to press into the bored hole to correct a diameter that has been bored oversize. This method can also be used to correct shaft holes that have worn elliptically in space plates.

Remember the rule: “If a tool chatters, reduce speed (RPM), increase feed (rate handwheel is turned) and take lighter cuts (boring head adjustment).”

CAUTION! WORK MUST BE SECURELY CLAMPED TO THE TABLE FOR BORING OPERATIONS.

Drill a hole as large as you can and still leave at least .060" (1.5mm) to finish bore. Decide the configuration of the boring head. The hole that accepts the boring tool can be indexed for large or small diameter holes. Use the combination that will keep maximum engagement of the boring head's dovetail.

FIGURE 2—Reversing lower portion of boring head for large or small holes.

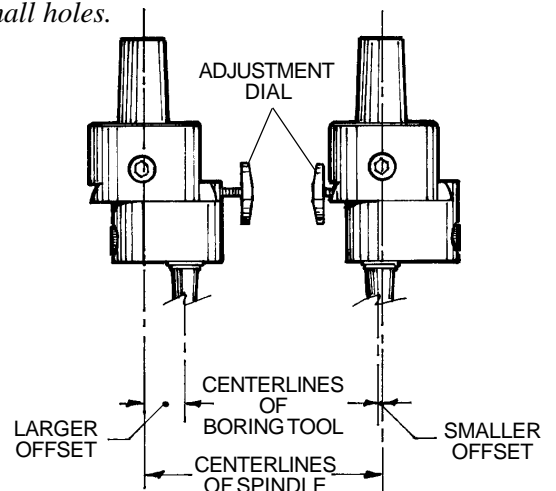

Clamp the boring tool into the boring head so the cutting face of the tool is in alignment with the center of the spindle.

Adjust the tool in or out to take approximately .020" (.5mm) cut in aluminum.

FIGURE 3—Fine adjustments of the Boring Head

One turn of the 4-40 screw dial will produce an increase of .050" in the bored diameter. Each increment on the dial is 7.2° which produces a rotation of the screw equivalent to .001" in the bored diameter.

Major increments are marked on the dial at 10 (.010"), 20 (.020"), 30 (.030"), 40 (.040") and 0 (.050").

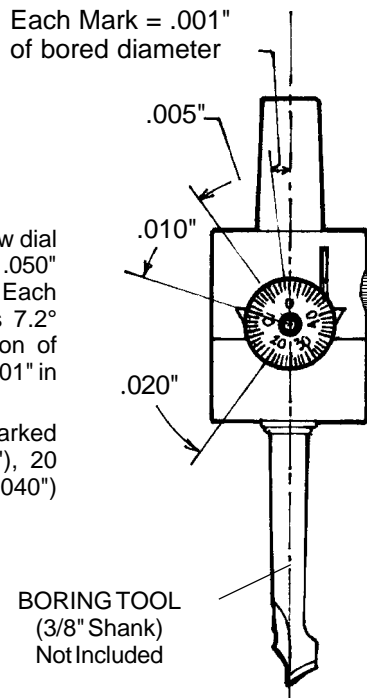

Note: Do not attempt to bore any metal other than aluminum or brass until you have the skill to hold exact diameters on these easier to machine materials.

Be sure the boring head screws are tightened properly and run the spindle at approximately 700 rpm or 1/4 speed. Take a cut by feeding the tool into the part at a rate that keeps making a continuous chip. Feeding too slow can cause chatter. A small amount of cutting oil will dramatically help the process.

Repeat this process until the hole is “roughed” out. Leave about .030" (.7mm) for finishing.

Before going to the finish diameter, determine that you can get a suitable finish with the tool you’re using. Take a light cut and stop the spindle at the bottom to inspect the finish. Start the spindle and back the tool out. Usually the tool will take a light cut on the way out. Stop the spindle and inspect the finish again. What you should learn from this exercise is where to stop your cut for the best possible finish; in or out?

If your tool needs sharpening, sharpen it before you get near the finish diameter. You can’t bore a hole any more accurately than you can measure it. Learn how to use small hole gauges and telescoping gauges. If you only have dial calipers, bore the hole and, if possible, turn the mating part on a lathe to fit the hole if a good fit is required. (It is easier to hold tight tolerance diameters on a lathe.)

From this point on it is best to “sneak up” on the finish diameter by taking half the cut required to get to the finish diameter. Cuts will keep getting smaller, and when you get to an error so small it would be hard to adjust the boring head .001" (.02 mm), try feeding the tool in at a higher RPM to bring the diameter to size.

Only the basics are written in these instruction and to make these basics work, it requires a liberal amount of common sense. If you have any doubts about a setup, it isn’t good enough! The skill of machining is making accurate parts on the first try. If this is your first attempt to use a boring head, bore a hole .575" or 16mm through a piece of aluminum approximately 3/8" (10mm) thick and see if you can come within .0005" (.025mm) on your first try. This will be a good test of your machining skills!

Good Luck,

—Joe Martin, President and Owner
Sherline Products Inc.

REPLACEMENT PARTS LIST

NO. REQ.	PART NO.	DESCRIPTION
1	3088	1/4-20 x 5-1/8" drawbolt and washer
1	3107	Gear drive pin
1	3156	4-40 x 7/8" skt. hd. cap screw
1	3157	Adjustment dial
1	3158	Boring head, primary (top)
1	3159	Boring head, secondary (bottom)
1	4034	10-32 x 1" skt. hd. cap screw
1	4057	3/32" hex key
1	4033	10-32 x 5/8" skt. hd. cap screw

SHERLINE 3/8" BORING TOOLS AVAILABLE

P/N 3061	Max. depth .6", Min. hole 1/4"
P/N 3063	Max. depth 1", Min. hole 5/16"
P/N 3064	Max. depth 1.5", Min. hole 5/16"

