



CHANGING DC MOTOR BRUSHES

Introduction

Sherline has been offering the DC motor since 1993, and it has provided very good service. We have sold a number of replacement brush sets, but, because we do not service the motors ourselves, we were not aware until recently that replacing the brushes requires some special techniques to keep from damaging the bearings. Because of the labor costs involved, it is more economical from our standpoint to replace the motor than to attempt to service it, but you can easily do the job if you use a few special techniques. The following sheet was developed to help you replace your brushes without damaging your motor.

The bearing in the brush plate can be damaged during reassembly if the main shaft is not supported when the bearing at the other end is pressed on. As the upper bearing is pressed back onto the shaft, the shaft is pushed downward. This transfers the force to the inner race of the lower bearings if the shaft is not supported. This can damage the bearings, which is indicated by a whining sound. Therefore, we have included a procedure to drill a hole in the end cap while it is apart. A supported pin or special fixture extends through the hole to support the end of the shaft during upper bearing reinstallation, thereby taking stress off the lower bearing. The hole is then simply covered up when the installation is complete.

Motors with external brushes

Sherline has recently become aware of an external brush version of this same excellent motor. Although it is more expensive, brushes can be serviced without disassembling the motor. Sherline plans to offer this motor in the future.

Tools required

5/16" and 3/8" wrenches, one of which should be a socket wrench, small wheel/bearing puller, 1/4" drill, soldering gun, arbor press, a length of pipe or tubing with approx. 5/16" inside diameter, approx. 3/16"-1/4" pin or special fixture to support end of motor shaft (see figure 5).

Disassembly

1. Remove the nuts on the end of the motor and take out the long screws that hold it together.
2. Pull out on the motor end plate where the shaft exits until it pops out of the body. It will go about 1/8" and then stop as the bearing at the other end gets stuck behind the brushes. Do not try to force the cap further or you will damage the brush plate.

3. Hook a wheel puller around the front cover and push against the shaft to remove the end cap and bearing from the shaft. NOTE: before removing the bearing, make sure the shaft is free from burrs so the bearing will come off easily. (See Figure 1.)

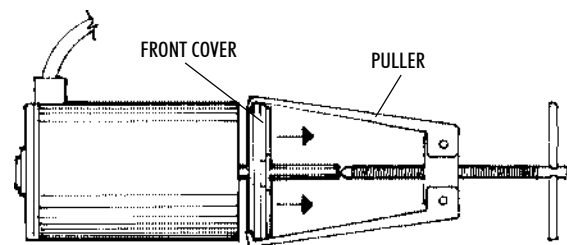

FIGURE 1—Using a bearing puller to remove the motor front cover and bearing.

4. Push the armature and rear cap from the motor body. (See figure 2.)

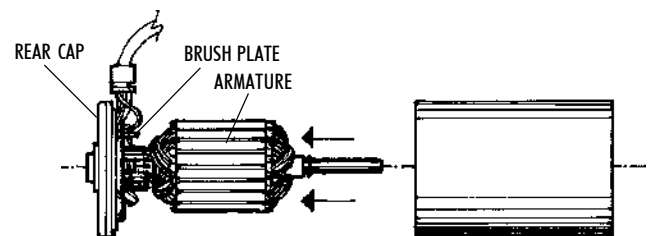

FIGURE 2—The end cap and armature are removed from the motor case.

5. Note the position of the brush springs. Then unclip them from the back of the brushes, release the tension on them and remove them from the brush plate. Set them aside in a safe place for reuse.
6. Push the brushes outward far enough so that the shaft and its bearing can be removed from the end plate.

NOTE: This would be a good time to clean up the surface of the commutator where the brushes rub. Use a Scotchbrite® or similar abrasive pad to clean the copper until it is bright and shiny. Then take a blade or sharpened wooden stick and lightly clean any debris out of the grooves between the individual copper commutator segments so that there is nothing that could cause an electrical short between segments.

Installing the new brushes

1. Remove the old brushes by cutting off the copper wire brush lead about 1/4" from the end near the plate. This will leave you enough wire to solder the new brush lead to.
2. Solder the wire on the new brushes to the end of the lead you left in step 1.
3. Drill a hole approximately 1/4" in diameter through the center of the end of the brush plate motor cap. (See figure 3.) Clean out any metal chips before reassembly.

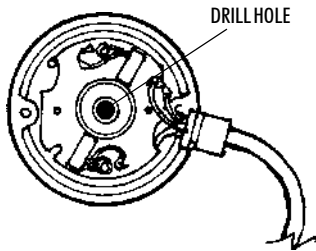

FIGURE 3—Drill a 1/4" hole in the center of the end cap.

4. Reinstall the armature shaft and bearing into the brush end cap. Install the new brushes into each brush housing, making sure the wire leads line up with the slot in the side.

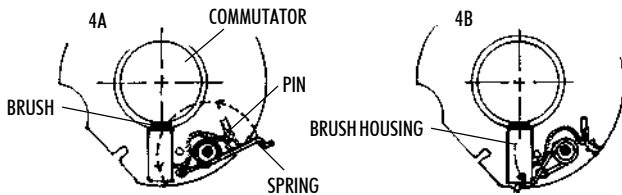

FIGURE 4—(A) Brush spring goes over pin with end of short arm in hole near edge of brush plate. (B) Bring long end of spring around counterclockwise and place it behind end of brush.

5. Reinstall the brush springs. (See figures 4a and 4b.) Slip a spring over the locating pin. Place the bent end of the short segment into the hole in the brush plate closest to the edge of the plate. Then wrap the long end around counterclockwise until the end can be snapped in place in the groove on the brush end, spring loading the brush against the commutator.
6. Rotate the motor shaft by hand to make sure the brushes run smoothly against the commutator and make good contact.

Reassembly

1. Slide the motor body down over the armature. HINT: Grip both the end cap and the large part of the armature with your free hand to keep the magnets from pulling the body down onto the end plate too rapidly. Loosen your grip on the armature and let the case slip slowly down the shaft, controlling the movement so it doesn't hit the end plate hard from the pull of the magnets. As the body nears the end plate, make sure the cutout in the end aligns with the slot in the cord sleeve and that the sleeve seats properly against the cap.

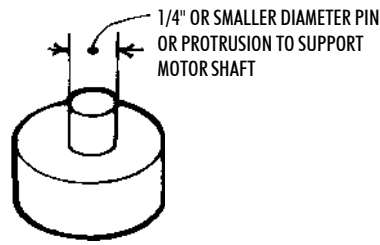

FIGURE 5—Shaft support fixture. This can be turned from metal on a lathe. As an alternate, any metal pin that can be properly held in a vise or a hole in a block of wood to support the end of the shaft during the reassembly process may be used. The support pin on the end must be of a size that will fit through the clearance hole you drilled in the end cap.

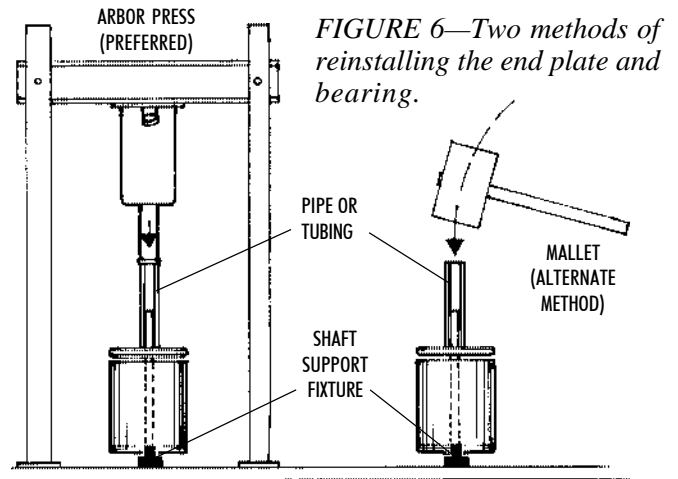

FIGURE 6—Two methods of reinstalling the end plate and bearing.

2. Use an arbor press to press the front cover and bearing back onto the motor shaft. (See figure 6.) Use a fixture similar to the one shown in Figure 5 or an equivalent method to support the end of the motor shaft while pressing the bearing onto the shaft. A tube with about a 5/16" inside diameter should be used over the motor shaft so that pressure is transferred only to the inner race of the bearing. NOTE: If an arbor press is not available, use the tubing and a mallet to gently and evenly drive the bearing down the shaft until the cap seats in the motor body. There is a bump on the perimeter of the cap that mates with a notch in the motor body to locate the cap in the proper position.
3. Reinstall the long bolts through the body from the brush end plate and install the nuts on the front cover end of the motor.
4. Use silicon sealant, tape or a sticker to seal the shaft support access hole you drilled in the end cap.

Running in new brushes

The motor shaft should spin easily by hand. New brushes may make a slightly different sound than you are used to until they have been run a while and have had a chance to seat against the armature. This is normal.

Joe Martin, President and Owner
Sherline Products