

Sherline DC Motor

Motor Mounting Instructions

1. Mount the Inner Belt Guard to the Motor using the two Standoffs (P/N 43100). Next install the Motor Pulley (P/N 43360) to the Motor Shaft and tighten the set screw.
2. Place Drive Belt over Motor Pulley.
3. Place round post on Speed Control Hinge Plate in hole on Inner Belt Guard.
4. Set Outer Belt Guard in place locating other post of Hinge Plate in its pivot hole. Motor Standoff ends will register in holes in Outer Belt Guard. Make sure the Drive Belt is routed properly. Then secure the cover with (2) 1-3/8" pan head screws which go into nuts pressed into the back of the Inner Belt Guard.

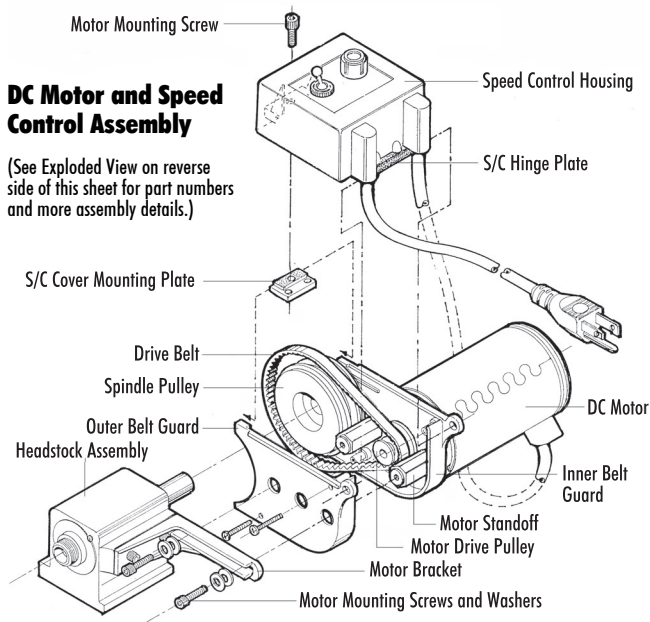

5. Place Drive Belt over Spindle Pulley and insert 10-32 x 3/4" socket head screws (with 2 washers on each) through Motor Mount slot and into holes in the ends of the Motor Standoffs. (These Standoff ends should be exposed through locating holes in the Outer Belt Guard.)

NOTE: The normal operating position for the Drive Belt is on the large diameter groove on the Motor Pulley and the small diameter groove on the Spindle Pulley. Use of the other (low RPM) position is discussed in the instructions below.

6. Tighten Motor Mount Screws, tilt Speed Control Unit out of the way and check the alignment of Drive Belt. It should be perpendicular to the Drive Pulleys. If it is not, loosen the set screw on the Motor Pulley and adjust it in or out on its shaft until the Drive Belt is square with the Motor.
7. Pull desired tension into Drive Belt by sliding the Motor Unit out in the Bracket Slot. Tighten Mounting Screws to hold the Motor/Speed Control unit in place.

NOTE: Do not overtension the Drive Belt. Just make sure it has enough tension to drive the Spindle Pulley without slipping under normal load. By not overtightening the belt you will not only extend its life, but will also provide a margin of safety for belt slippage should a tool jam in a part or an accident occur. The belt must be a little tighter when used in the low speed range because small diameter pulleys are not as efficient.

8. Set Mounting Plate into top of Belt Guard Housing so it rests on rails molded onto inside surfaces of housing. (The pressed-in nut goes down and to the outside.) Slide the plate toward the outside (toward the Spindle Pulley) until it stops. NOTE: The Mounting Plate was designed to be easily removable so it is out of the way when adjusting the Drive Belt position.

9. Rotate Speed Control unit into place and insert the single 10-32 x 3/8" socket head screw through hole in Speed Control Housing and into Nut in Mounting Plate. Tighten enough to hold in place. *Do not overtighten.*

10. NOTE: Those of you who machine a lot of wood or brass may want to purchase and install a switch cover (P/N 3015) to keep the fine dust out of the power switch. The wood dust can gum up the switch causing intermittent operation. Brass dust can short out the switch or cause a risk of electric shock to the operator. The cost of the cover is \$5.00.

Why Sherline now uses a DC motor

All the photos in the color *SHERLINE Instruction Guide* show the AC motor and speed control used through 1992. The increased complication of the Speed Control unit for DC drive had deterred us from offering DC power until now. We think you will agree the switch to DC is one that was worth the effort and will increase the utility of Sherline tools even further.

The first thing experienced Sherline users will notice is the new motor is much quieter. When you begin to take cuts with it, you will also notice that DC power offers a great advantage in torque. Comparing horsepower figures between the two is not even valid, as the measurements are deceiving. You will find the new motor offers much more usable power than the previous 1/2 HP AC motor. You still get smooth, continuous adjustment to 2800 RPM with the electronic speed control. In addition, the new two-position pulley system offers even further speed range by giving you the option to gear it down even further using the new low speed/high power position. This position is very helpful when turning large parts or when low RPM is needed.

We are quite pleased with the operation of the new DC motor and are sure you will also find it is a great addition to the ever-expanding capabilities of the Sherline miniature machine tool line. You are now the owner of the smoothest, quietest and most powerful Sherline tool ever offered. Welcome to the world of miniature machining!

CAUTION—Motor is thermally protected

Thermal protection means there is a built-in circuit breaker that will shut down the motor if it gets too hot. This keeps the motor from burning out. The breaker will automatically reset as soon as the motor cools and you can go back to cutting, but you should be aware of how it works and what to do if the machine suddenly shuts itself down. If your motor is shutting down from overheating on a regular basis, it means you are taking too heavy a cut or operating at too high an RPM for long periods. Slow your speed down, reduce your cut or feed rate and you should have no further problems.

Due to the nature of miniature machining, overloading the machine is a common problem. It is often tempting to try to speed up the process by working faster. Keep in mind this is a small machine and work with patience and precision--don't be in a hurry. Your parts will come out better and your machine will last much longer if it is not overstressed.

What to do if the motor shuts down

If your thermal protection circuit shuts down the motor while work is in progress, immediately shut off the power switch and then back the tool out of the work. It should only take 10 seconds or less for the circuit breaker to reset, then you can turn the motor on and start the cut again, this time putting a little less stress on the motor. If you leave the tool engaged in

the part and the power on, when the circuit breaker kicks back on, the motor must start under load. This can be very hard on your motor.

Thermal protection is built into your motor to make sure it is not damaged by overloading. Use good common sense when operating the motor, and it will provide many years of trouble free operation.

Exploded View

DC Motor Parts List

PART #	DESCRIPTION
30220	Toggle Switch Lock Ring
30230	Toggle Switch
31080	Cup Point Set Screw, 10-32 x 3/8"
32100	Hex Nut, 10-32
40040	Drive Belt
40440	Self Tapping Screws (2)
40510	Skt. Head Cap Screw, 10-32 x 3/8"
40520	Cup Point Set Screw, 10-32 x 3/16"
40620	110 V. AC Power Cord and Plug
40660	Washers (4), 3/16" I.D.
40670	Skt. Hd. Cap Screw, 10-32 x 1/2"
40690	Skt. Head Cap Screw, 10-32 x 3/4" (2)
41080	Hex Nuts (2), 6-32
41130	Speed Control Knob and Set Screw
43100	DC Motor Standoffs (2)
43110	DC Speed Control Cover
43120	DC S/C Hinge Plate
43130	DC S/C Cover mounting Plate
43140	S/C Tab, Small
43150	S/C Tab, Large
43160	Belt Guard (Outer)
43170	Pan Head Screws(2), 6-32 x 1-3/8"
43180	Belt Guard (Inner)
43190	Flat Head S/M Screws (2), #2 x 1/4"
43200	DC Speed Control Label
43230	Stepped Headstock Pulley
43360	Stepped Motor Pulley
43450	DC Motor
43460	DC Electronics
90060	5K Potentiometer
90080	Hex Nut, 3/8" x 32

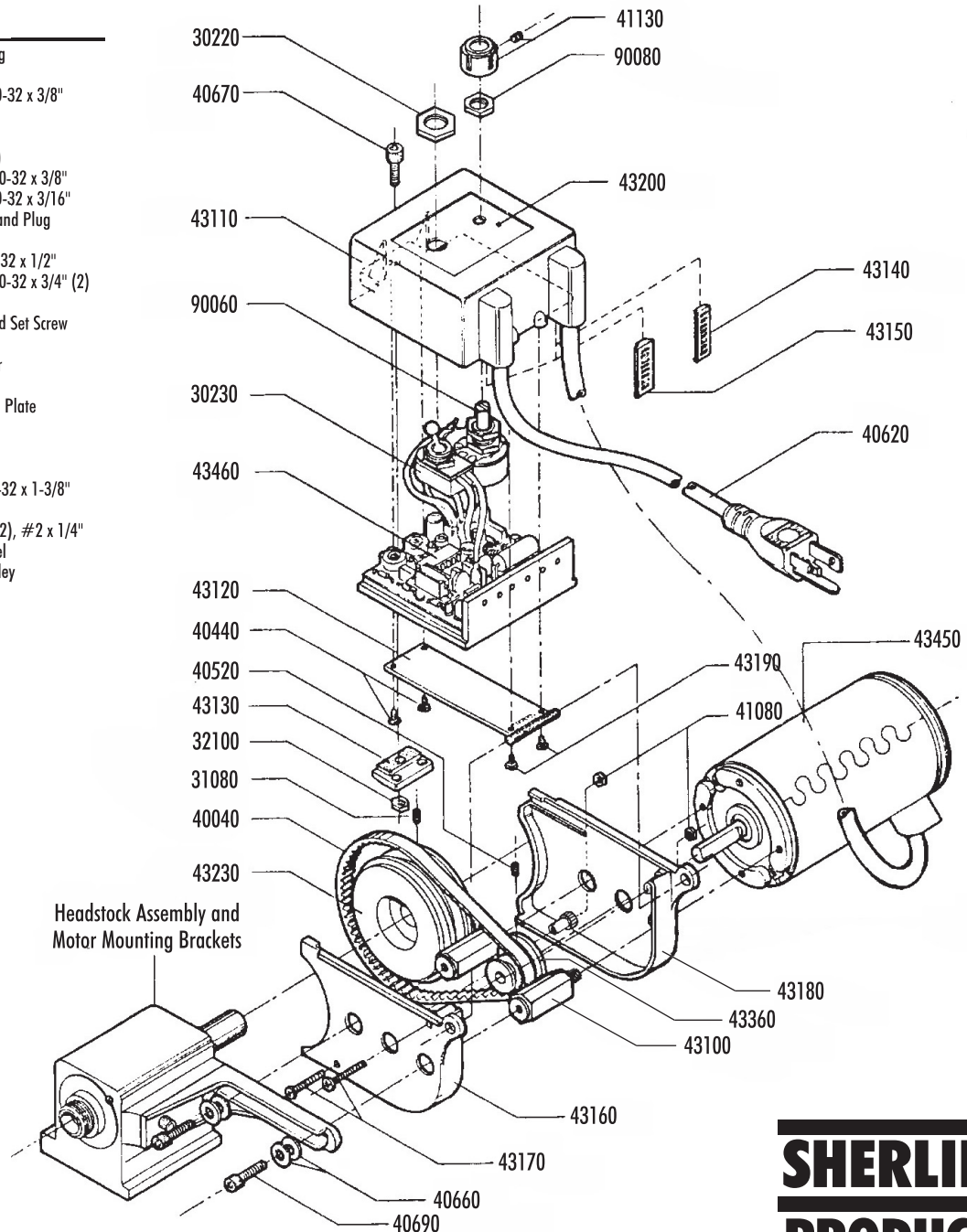

SHERLINE
PRODUCTS
INCORPORATED 1974