

Sherline Manual 5000- and 5400-Series Vertical Milling Machines

NOTE: Where different, Inch part number is given first, followed by Metric part number.

Exploded View and Part Numbers

NOTE: Some factory assembled machines may have a 0.005" shim washer P/N 40030 (not shown) placed between the handwheel and thrust to adjust backlash. If removed when servicing the machine they should be replaced in the same position.

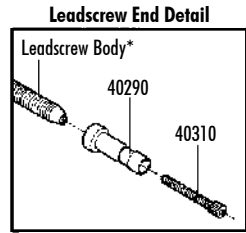
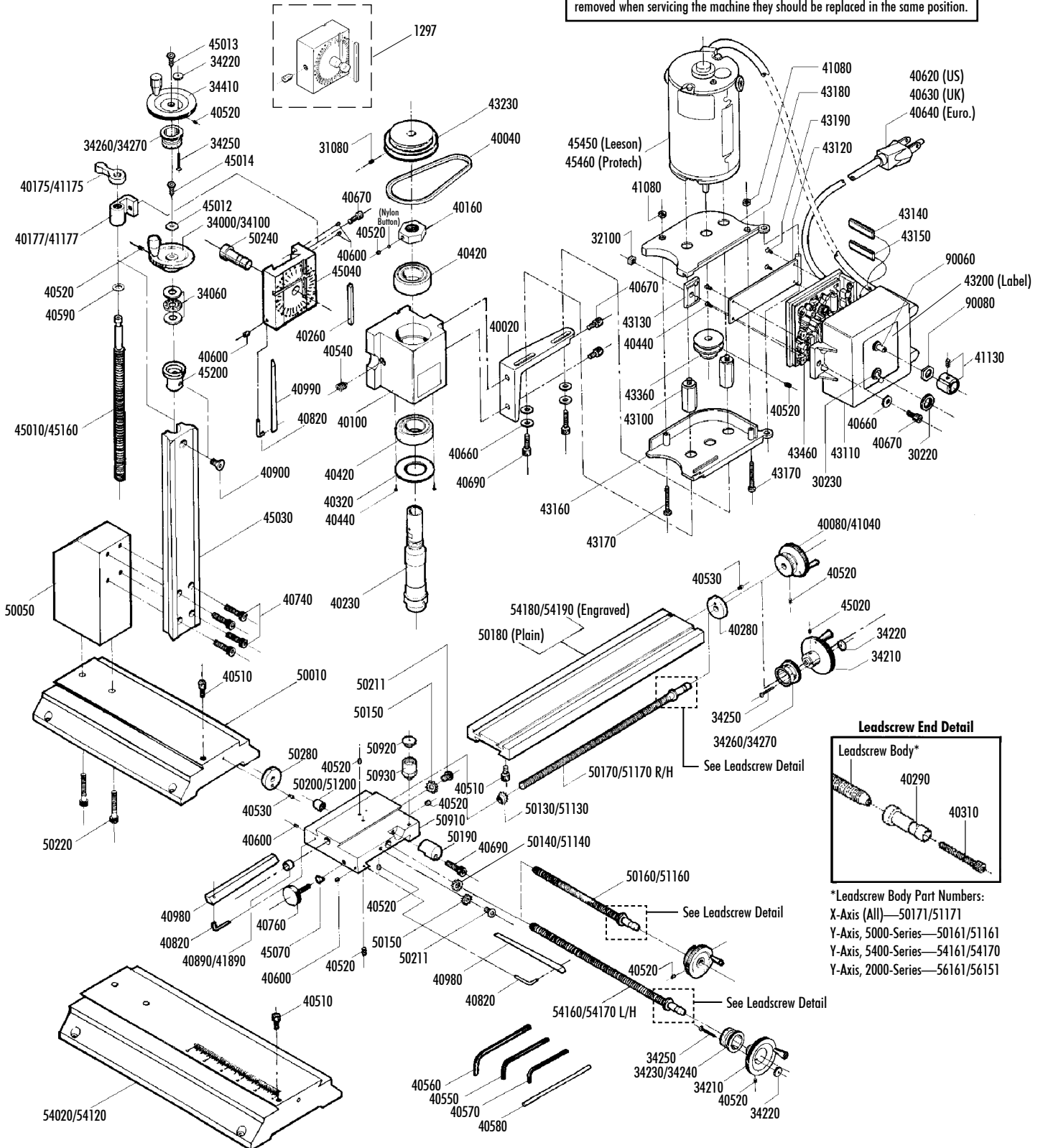

*Leadscrew Body Part Numbers:
 X-Axis (All)—50171/51171
 Y-Axis, 5000-Series—50161/51161
 Y-Axis, 5400-Series—54161/54170
 Y-Axis, 2000-Series—56161/56151