



# **Installing CNC Stepper Motor Mounts On A Sherline Mill**

**P/N 6700 (6710 Metric)-5000/5100/5400/5410 Mills**

**P/N 6705 (6715 Metric)-2000/2010 Mills**

---

## ***USING THE TEMPLATE BLOCKS TO LOCATE NEW MOUNTING HOLES FOR THE STEPPER MOTOR MOUNTS***

This kit contains two template blocks that will help you locate the holes needed to fit stepper motor mounts to your existing Sherline lathe or mill. (Sherline machines manufactured after 9/99 now have the table and mill base holes predrilled to make this job easier.) The rectangular block is used for the lathe crossslide table and mill table as well as the mill base. The round template is used for the lathe bed (leadscrew) and the mill column bed (Z-axis). These blocks are not hardened, because they will only be used once or twice and the wear on them will be minor. To drill the hole pattern for the stepper motor mount for each axis, follow the steps below:

1. Using the handwheels, move the table and saddle so that they are as close to the handwheel as possible.
2. On models with standard handwheels, break loose the 5-40 screw in the center before removing the handwheel. The handwheel gives you a way to hold the leadscrew while breaking the center screw loose.
3. Remove the handwheel by loosening its set screw with a 3/32" hex wrench and pulling it off the shaft. (For adjustable "zero" handwheels, rotate the red collar until the hole lines up with the set screw.)

4A. Remove the leadscrew thrust from the appropriate base, table or column. It is held on by a single 5-40 screw. The mill column thrust is held in place by a countersunk screw through the bed.

4B. X- and Y-axes-Remove the 5-40 screw from the end of the leadscrew. Set aside leadscrew end, thrust and 5-40 screws. They are no longer needed. (On machines with adjustable zero handwheels, use pliers with plastic jaws to hold the leadscrew or protect the leadscrew threads in some other way while holding it to break loose the 5-40 screw.)

4C. For the Z-axis only, remove the screw that holds the saddle nut to the saddle. (Hold the saddle so it doesn't drop when the screw is removed.) Remove the leadscrew and saddle nut. A new leadscrew is provided. It is already attached to the stepper motor mount. Install your saddle nut on the new leadscrew. NOTE: If you have a Z-axis locking lever, we recommend that it not be used when converting to CNC use. Reinstall the saddle nut only.

5. If there are not already holes drilled and tapped in your table and base, bolt the template parallel to the table or base to be drilled using the center hole and one of the 5-40 SHCS provided with the kit. Once level with the table, clamp it in place so it can't move. (Mills made after 2002 will have these holes already in place.)

6. If mounting holes are not already present, using a "C" clamp, clamp the template to the mill column with the hole pattern leveled. (See Fig. 2.) Measure the height of each hole from the top surface unless you are pretty good at knowing when something is level by eye. It is not critical to its function that the stepper motor is mounted level, but it looks much more professional when it is.

7. Using the holes in the template as a drill guide, start each hole about 1/16" deep with a #29 or .136" drill.

8. Remove the template block and finish drilling the holes to .25" deep, backing the drill out to clear chips, add cutting oil and finish drilling the hole in two more steps until a depth of 0.5" is reached. Countersinking the holes will make it easier to start a tap.

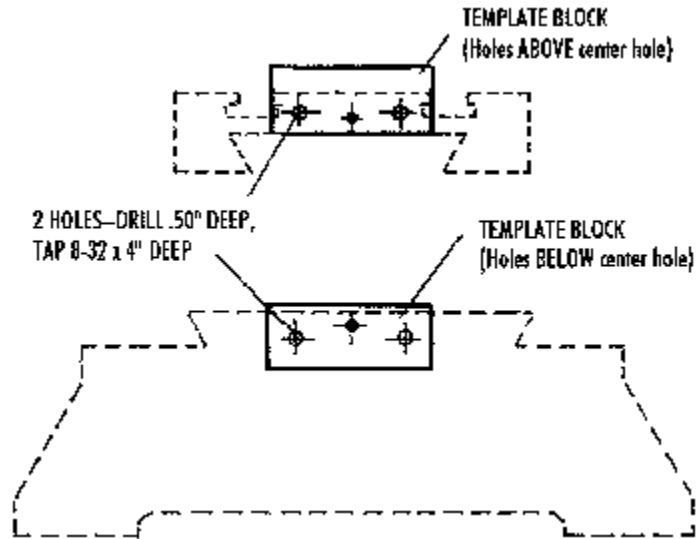

FIGURE 1-The rectangular block (P/N 67117) is used for the lathe and mill tables as well as the mill base. On the tables, the two new drilled holes are ABOVE the existing center hole, while on the mill base, the two new holes go BELOW the center hole as shown in the drawings above.

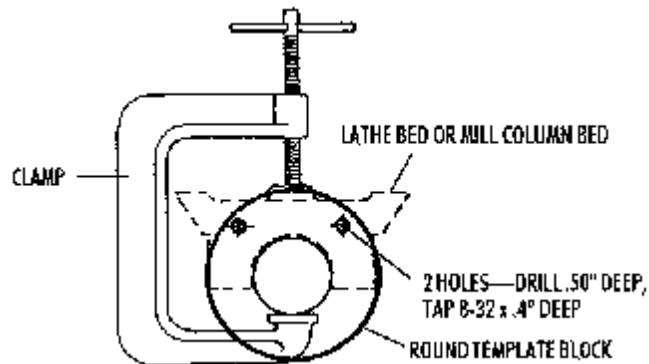

FIGURE 2-The round center of the template block (P/N 67116) registers in the center portion of the column bed. Rotate the template until the holes are level and clamp in place while starting holes.

9. Tap the holes to 8-32 to at least .4" deep. Be sure to use cutting oil. Remember that you are working on part that is relatively expensive to replace. Take your time. Remove any burrs from the surface of the part after tapping the hole.

### **INSTALLING THE STEPPER MOTOR MOUNT**

1. Thread the proper preload nut onto the leadscrew based on its direction of rotation (left-hand or right-hand).
2. Slide the stepper motor mount over the X- or Y-axis leadscrew end.

3. Push a coupler through the bearings and over the tapered end of the leadscrew. Attach it to the leadscrew with the new 5-40 screw provided. To tighten, put a hex key through the hole in the side of the mount and into the handwheel shaft set screw. Hold the key to keep the shaft from turning while tightening the 5-40 SHCS in the end of the coupling. (See figure 3.)

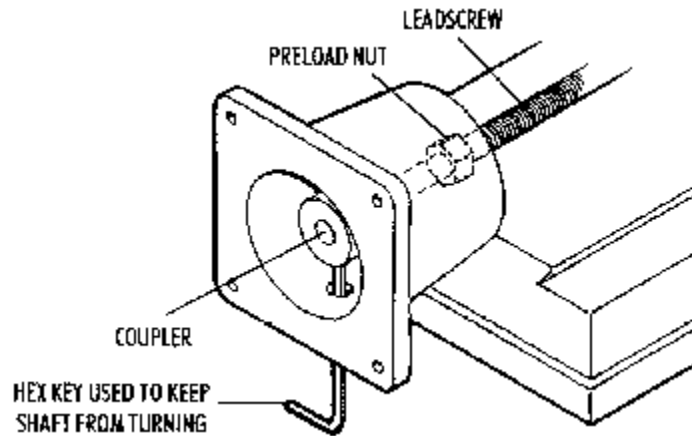

*FIGURE 3-Keeping the leadscrew from turning while tightening 5-40 screw and the preload nut. Note that now the access hole has been moved to the side of the mount rather than on the bottom as is shown here.*

4. Using a 3/8" wrench, adjust the preload nut snugly against the end of the bearing. (Note the direction of rotation; i.e., left- or right-hand threads.) Tighten it enough to remove all endplay. (See Figure 4 to understand how the nut preloads the bearings.) Turn the coupling by hand to make sure it turns freely, then put a little LocTite® on the threads behind the preload nut and let capillary action draw the fluid in. Figure 3 shows how to use a hex key through the hole in the mount to keep the coupler from turning while tightening the preload nut.

5. With the leadscrew screwed into the mill saddle as far as practical and the table moved to its extreme left position, attach the stepper motor mount to the table, base or bed by installing two 8-32 x 3/4" SHCS provided. They go inside the motor mount and thread into the new holes in the bed, base or table. Before tightening the screws, turn the coupler by hand to make sure the mount is properly aligned and is not putting tension on the leadscrew. The holes in the mount are slightly oversize to allow for minor alignment adjustments. Check for proper alignment by again hand-turning the coupler to assure there is no binding after final tightening of the screws.

6. Put the Z-axis leadscrew/stepper motor mount assembly in place and re-attach the saddle nut to the Z-axis saddle using the screws from the old saddle nut. It will be necessary to readjust Z-axis saddle nut after installation. (See instructions that follow.)

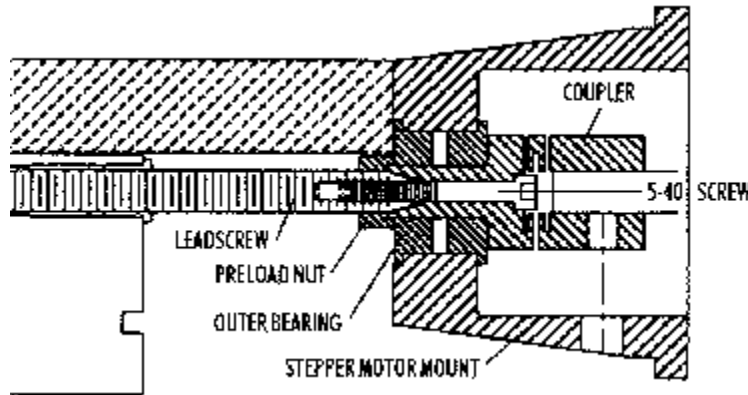

FIGURE 4-A cross-section of the stepper motor mount shows how the coupler is attached to the leadscrew.

### **ATTACHING A STEPPER MOTOR TO THE MOUNT**

Sherline stepper motors come with a flat machined on the shaft in the proper location. If you are using another stepper motor, a flat must be filed or machined where the coupling set screw is to be tightened against it. See the cross-section on the attached sheet for location of the flat. File a flat or use your mill to machine a flat on the shaft. (If a flat is not provided, the set screw will raise a burr, making it difficult or impossible to remove the shaft from the hole later.) Push the shaft into the coupling and tighten the set screw on the flat. Attach the stepper motor to the mount using the three SHCS provided. The fourth hole can be used for a "cable tie" to secure the cable or for a fourth screw at your discretion. Attach a handwheel to the shaft on the other end of the stepper motor.

### **ADJUSTING THE Z-AXIS SADDLE NUT**

*(Following is a review of how to adjust the saddle nut after the new Z-axis leadscrew is installed.)*

The adjustment for the saddle nut consists of two flat set screws on either side of a 10-32 socket head cap screw. With the saddle nut located on the leadscrew close to the stepper motor mount, loosen these two screws and slide the saddle into position over the saddle nut. Put the 10-32 socket head cap screw through the saddle and screw it into the saddle nut, but do not tighten it yet.

Adjust the set screws until the flat points touch the saddle nut, and then tighten the 10-32 socket head cap screw. Watch as you tighten to see that the leadscrew doesn't move. If it does, loosen the screw, readjust the set screws and retighten.

What we are attempting to accomplish is to have the saddle nut ride on the leadscrew with the minimum amount of drag. You can check the drag by turning the leadscrew handwheel. If you feel drag, tighten or loosen a single set screw while moving the saddle with the handwheel until the handwheel turns freely, but keep the saddle close to the handwheel. If you adjust the saddle nut while it is in the center of the leadscrew, it may be slightly off center but will feel free until

the saddle gets close to either end of its travel. Here, the leadscrew is supported and cannot deflect so it will bind. If you can't eliminate the binding, tap the saddle nut with a plastic hammer on the leadscrew side while the saddle nut is tightly attached to the saddle and readjust. Don't use the machine with a loose attachment screw as this will cause excessive wear and backlash.

-Joe Martin  
Sherline President and owner