

WHITE ENSIGN MODELS

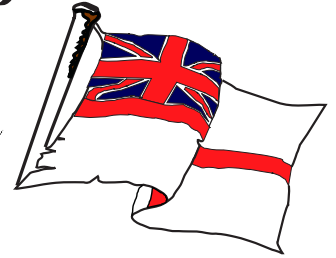

USS Indianapolis (CA-35) Heavy Cruiser

Photoetched Metal details to fit the Academy and Trumpeter *Indianapolis* kits in 1/350 Scale

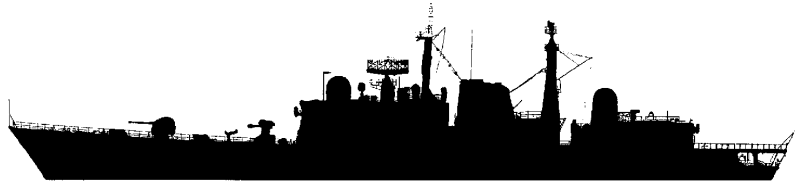
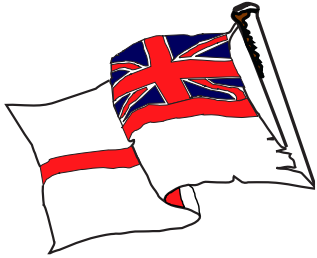

General Instructions when using Photoetched Parts

1. Do not remove the etched parts from the fret until you are ready to use them.
2. Before assembly, soak the etched parts in a suitable solvent, such as white spirit, to de-grease the surfaces for painting.
3. Cyanoacrylate adhesive (super glue) or contact adhesive such as Elmers white glue may be used. These can be applied with a pin or piece of stretched sprue.
4. When removing parts from the fret, place the fret on a hard surface, such as a smooth ceramic tile, in order to prevent parts bending whilst cutting through the holding tabs. We suggest using a #11 type of modelling knife blade for this purpose.
5. When shaping or bending a part, a straight edged blade such as a chisel blade #17 or # 18 will give a good sharp corner; alternatively a small pair of smooth-jawed pliers may be used.
6. If a part is bent incorrectly, lay it on a hard flat surface and roll it flat with a cylindrical object such as a modelling knife handle.
7. We suggested that stock rails are pre-measured, where practical, using a pair of compass dividers and then tacked to the deck edge every third or fourth stanchion with a small drop of glue. When a section is complete, run a thin line of glue along the inside edge to attach it firmly to the deck.

INTRODUCTION

1. This detail set has been designed principally around the Academy kit and the instructions also make reference in this way. Provision has been made with items such as tailored-to-fit railings, for these to be adapted to fit the Trumpeter kit by inserting additional sections of railing that are supplied as etched parts 57, where required.
2. Where the Trumpeter kit has been provided with photoetched parts, these are to be used in preference to those supplied in this set if there are huge differences in the shape and fit of the items.
3. Where reference is made to kit parts, the Trumpeter kit part number will follow afterwards in brackets throughout these instructions.
4. Certain parts have been included in this set that will allow the modeller to backdate the *Indianapolis* to her early war appearance. Further research will be required to do this, though assembly instructions for the actual parts are included.
5. Separate sets of USN Pattern Doors & Hatches and also USN Cable & Hawser reels are also available from White Ensign Models.
6. While every effort has been made to ensure as full an explanation as possible of the parts included in this set and their assembly to the relevant kit, sometimes one or two items may appear to get overlooked. If there are no assembly diagrams in the main part of the instructions, then there should be a text explanation in the other instructions section or a location of parts provided in the parts list. If there is still difficulty in establishing how a part is assembled or located on the kit, contact White Ensign Models and we will be pleased to help resolve the problem.

© WHITE ENSIGN MODELS LTD. 2013

Unit 5, Cobnash Industrial Estate, Kingsland, Leominster, HR6 9RW, U.K. Tel. 0844 415 0914 Fax 0844 415 0916
E-mail: wem@onetel.com Website: <http://WhiteEnsignModels.com>

Customers in the USA can now call us on 011-44-1568-709149 or Fax 011-44-1568-709182

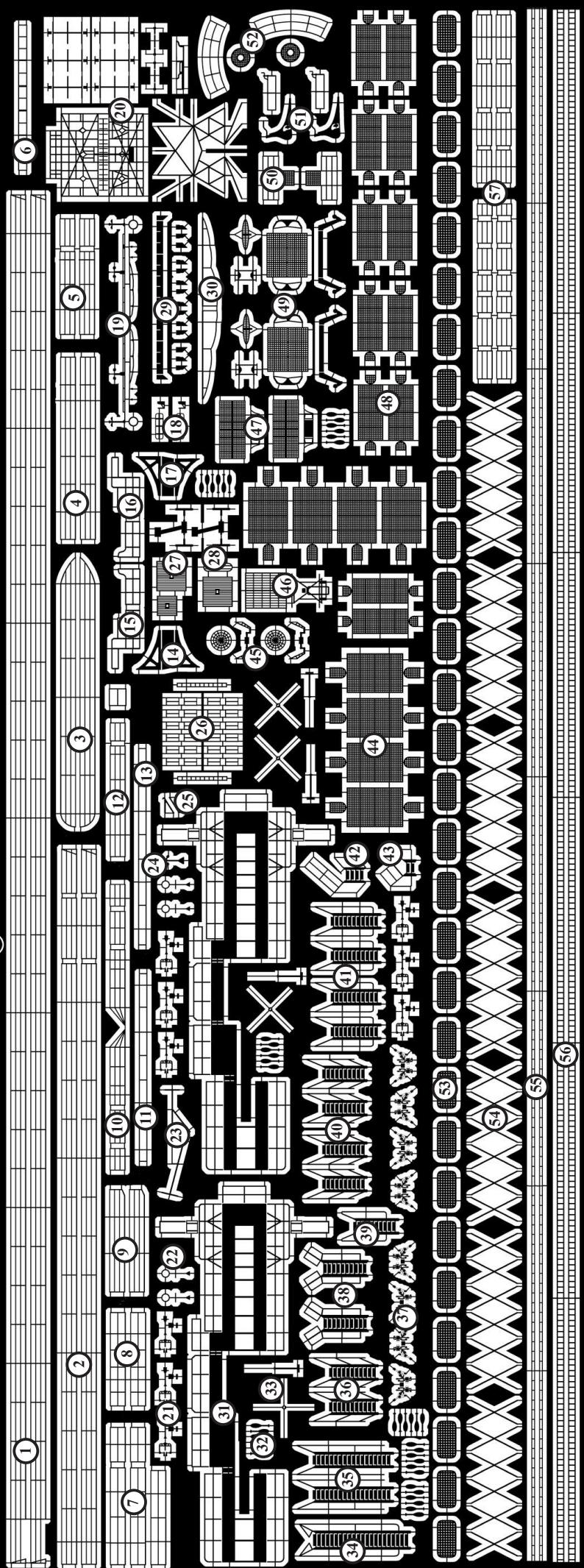

- | | | | |
|--|--|------------------------------------|---|
| 1. Railings (Foc'sle Deck) | 27. TDY Antenna | 53. Rectangular Life Raft Bases | 79. Mainmast Platform |
| 2. Railings (Fantail) | 28. TDY-1 Antenna | 54. Life Raft Retainer Straps | 80. Mainmast Platform Rear Supports |
| 3. Railings (Catapult Deck) | 29. Bridge Wind Deflector Venturi | 55. Handrail Stock | 81. Mainmast Platform Forward Supports |
| 4. Railings (Aft Gun Deck Rear) | 30. Mainmast Yardarm Footropes | 56. Vertical Ladder Stock | 82. Funnel Cap Grilles |
| 5. Railings (Hangar Roof Deck Aft) | 31. Aircraft Catapult Walkways | 57. Railing Adapter Inserts | 83. Hangar Doors |
| 6. Bridge Windows | 32. Life Raft Paddles | 58. Aircraft Catapult Assembly | 84. Lower Bridge Wing Supports D50 |
| 7. Railings (Aft Funnel Deck D49) | 33. TBS Antennas | 59. Aircraft Launch Cradle | 85. Rear Bridge Platform Supports |
| 8. Railings (Foremast Director House) | 34. Inclined Ladder (Catapult Deck Aft) | 60. Early Boat Crane Jib | 86. Aft Funnel Catwalk |
| 9. Railings (Aft Gun Deck Side) | 35. Inclined Ladders (E35) | 61. Early Boat Crane Rigging | 87. SOC Seagull Parts |
| 10. Railings (Catapult Deck Ladderways) | 36. Inclined Ladders (E49) | 62. Mainmast Triangular Platform | 88. Captain Top Plates |
| 11. Railing (Mainmast Platform) | 37. Mk 51 Director Sights | 63. Early Boat Crane Tripod Legs | 89. Platform Supports D2 |
| 12. Railing (Crane Base Platform) | 38. Inclined Ladders (E10) | 64. Crane Hook | 90. Propeller Guards |
| 13. Railing (Foremast Platform) | 39. Inclined Ladder (Bridge Rear) | 65. Foremast Platform | 91. Mk 8 Fire Control Antenna Mounting |
| 14. Catapult Access Platform [Port] | 40. Inclined Ladders (E9) | 66. Director Tower Supports | 92. 40mm Ammunition Clips (Forward Tubes) |
| 15. Railings (Port Catapult Access Platform) | 41. Inclined Ladders (Aft Gun Deck) | 67. Bridge Front Supports | 93. 40mm Ammunition Clips (Amidships Tubes) |
| 16. Railings (Sbd Catapult Access Platform) | 42. Inclined Ladders (Aft Funnel Vent Lower) | 68. Aircraft Handling Trolleys | 94. 40mm Ammunition Clips (Fantail Tubes) |
| 17. Catapult Access Platform [Starboard] | 43. Inclined Ladder (Aft Funnel Vent Upper) | 69. Main Aircraft Crane | 95. 40mm Bofors Mounting Fittings |
| 18. SG Radar Antennas | 44. Floater Net Baskets (Deep Fill) | 70. Accommodation Ladder Handrails | 96. Deck Swabs |
| 19. Foremast Yardarm Footropes & Details | 45. Mk 28 Fire Control Radar Antenna | 71. Accommodation Ladder Steps | 97. Twin 20mm Oerlikon Mountings |
| 20. SK Radar Antenna | 46. SC Radar Antenna | 72. Accommodation Ladder Rigging | 98. Single 20mm Oerlikon Mountings |
| 21. Sky Lookouts | 47. Mk 3 Fire Control Radar Antenna | 73. Fire Hose Points | 99. Anchor Chain Stoppers |
| 22. ESM Antennas | 48. Floater Net Baskets (Shallow Fill) | 74. Platform Supports C23 | 100. Crane Rigging |
| 23. Foremast Platform Antennas | 49. Mk 4/Mk12 Fire Control Radar Antenna | 75. SOC Seahawk Parts | 101. Anchor Chain Stock |
| 24. Foremast Platform Mid Antenna | 50. Leadsman's Platforms | 76. Mainmast Top Platform | 102. Oval Life Raft Bases. |
| 25. Wire Antennas Locating Brackets | 51. Whaleboat Fittings | 77. Mast Top DF Antenna | |
| 26. Mk8 Fire Control Antenna Dipoles | 52. Mast Top SG Radar Platforms | 78. Fore Funnel Catwalk | |

© WHITE ENSIGN MODELS 2013

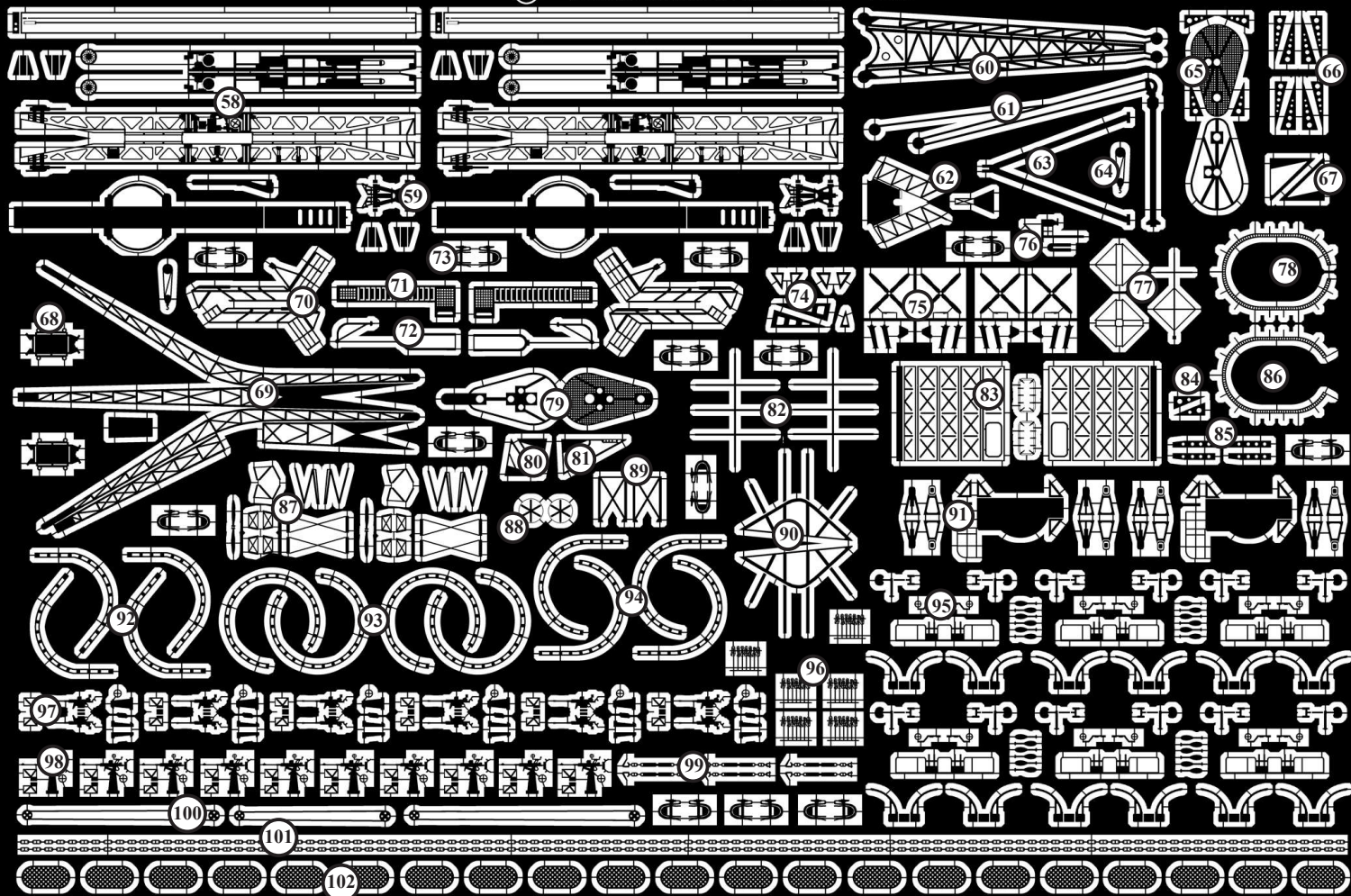

SK RADAR ANTENNA ASSEMBLY

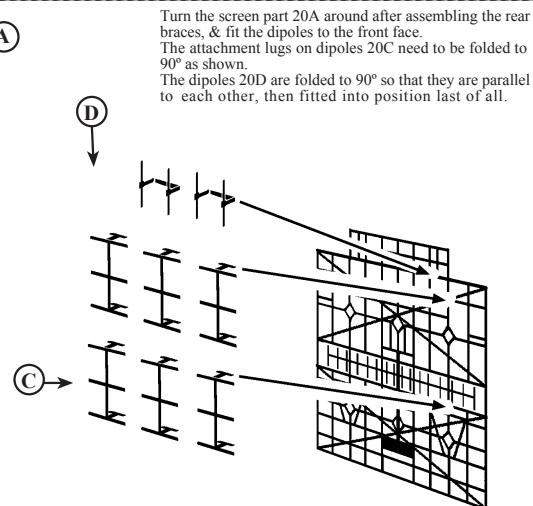
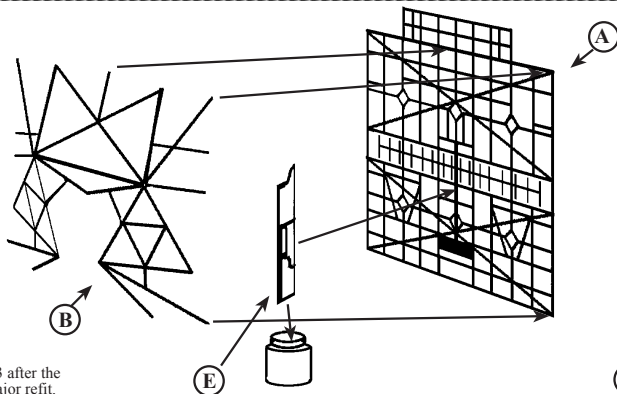
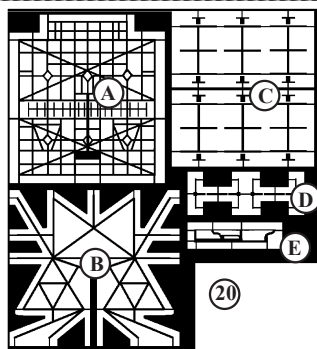

Turn the screen part 20A around after assembling the rear braces, & fit the dipoles to the front face. The attachment lugs on dipoles 20C need to be folded to 90° as shown. The dipoles 20D are folded to 90° so that they are parallel to each other, then fitted into position last of all.

The SK radar antenna assembly was fitted from 1943 after the mainmast was rebuilt over the aft funnel during a major refit. Fit the waveguide mounting frame 20E to the mounting pintle supplied as kit part D12. (C28) Attach 20E to the back face of the screen part 20A as shown. Fit the rear bracing frame 20B to the back face of the screen, folding in the extremities to fit around the outer edge at the points shown. The rear bracing frame stands well away from the screen & it may take a few attempts to get the extremities folded in to the right places for attachment.

SG RADAR ANTENNA

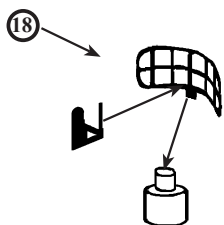

The SG radar antennas were fitted to the mast tops of both the fore & mainmasts according to some sources. The etched parts replace the moulded plastic item on kit part D8 (C11). Gently curve the antenna dish & fit to the rear upright on the central single dipole. Fit this assembly to the moulded plastic spigot left on the mast top after the plastic antennas has been removed.

SC RADAR ANTENNA

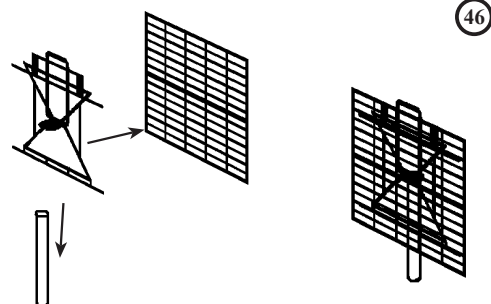

The SC radar antenna was fitted to most of the ships of the class from around the end of 1942 on the foremast platform, before the foremast was altered. Fit the backing frame of etched part 46 directly onto the front grille as shown. Cut a length of 1mm plastic rod & fit centrally as a mounting spindle. This part can be used if the model is to be backdated. Further research will be required to establish correct platform location details.

MK 3 FIRE CONTROL RADAR

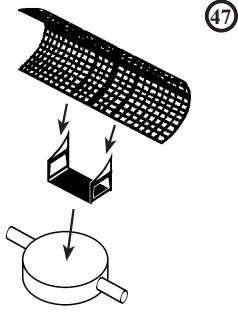

This antenna was fitted as the main fire control radar early on in the war years until replaced by the Mk 8 unit. This assembly is provided for backdating the kit if desired. Shape the antenna grille of etched part 33 as shown above & fit to the etched support frame. Fit the whole assembly centrally to the plastic base plate from the kit part E37 (D40). Make two of these.

MK4/MK12 FIRE CONTROL RADAR & MK22 HEIGHT FINDER

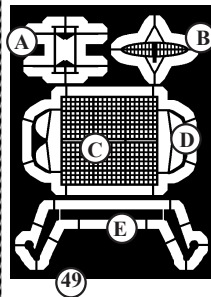

This fire control radar antenna was fitted to the front of the Mk37 directors, before the circular Mk 28 was fitted. Whether or not this antenna was upgraded to the Mk12 at any time will require further research when using this item to backdate the kit.

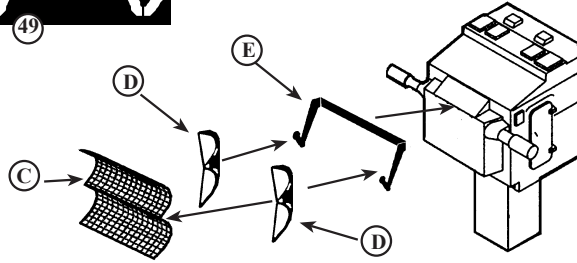
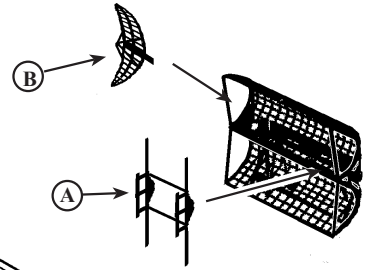

Shape etched part 49C to give a double curvature as shown left, then fit the end frames, etched parts 49D into place. Shape the mounting bracket, etched part 49E, so that the two arms are folded to 90° & then fit to the front of the director after first removing any moulded plastic parts from the surface that are not required.

TDY 7 TDY-1 ANTENNA ASSEMBLY

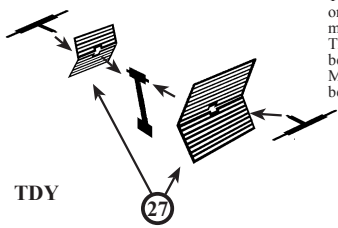

Two types of TDY antennas were available, one of which appeared to be fitted on the fore mast platform. The layout of these assemblies is shown left & below & shows how the screens are shaped. Most likely the TDY antenna was fitted & can be used to replace kit part G6 (C25/PE18).

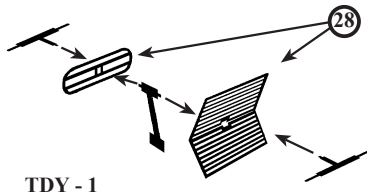

MK 28 FIRE CONTROL

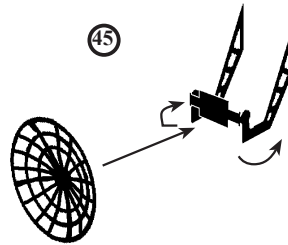

The small Mk 28 fire control radar dish was fitted to the front face of the Mk37 directors, fore & aft. The circular antenna needs to be dished slightly with an embossing tool. Fold the mounting legs to 90° so that they are parallel, then fit the legs to the front face of the main director. These assemblies replace kit parts E74 (D58/PE25).

MK51 DIRECTOR DETAILS

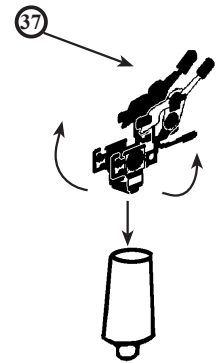

Fold up the sides of etched parts 37 to 90° so that they are parallel. These parts can be used to replace the top sections of kit parts E69 (E30) if desired.

MAST TOP DF ANTENNA

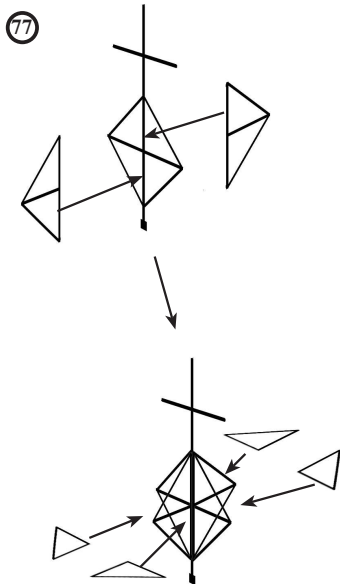

The mast top DF antenna, etched part 77, has been supplied to fit to kit part D7 if the mainmast top part is being retained. It replaces kit part PE8 in the Trumpeter kit. Assemble the two vertical sections to the main antenna array central vertical post as shown top. Fit the angled quarter sections so that they fit in & attach to the horizontal cross bars as shown above. This assembly can be used as part of the mainmast reconstruction that is dealt with in a later section.

AIRCRAFT HANDLING CRANE

This assembly is for the main aircraft crane jib, & is supplied to replace the moulded plastic kit part D58 (or PE15 in the Trumpeter kit).

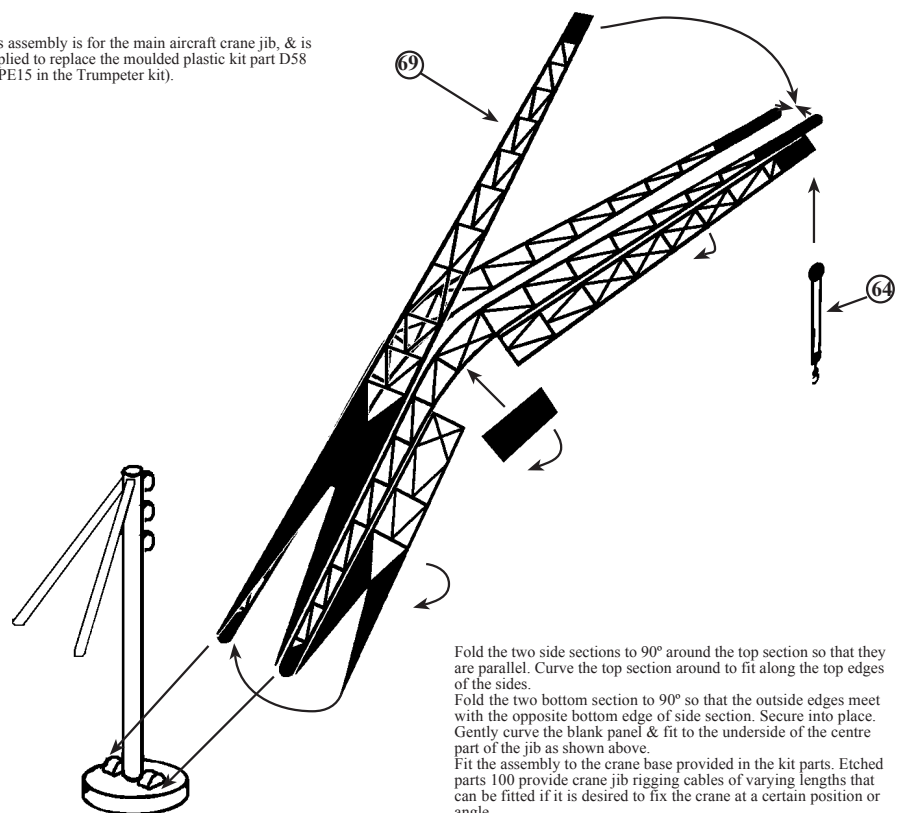

Fold the two side sections to 90° around the top section so that they are parallel. Curve the top section around to fit along the top edges of the sides. Fold the two bottom section to 90° so that the outside edges meet with the opposite bottom edge of side section. Secure into place. Gently curve the blank panel & fit to the underside of the centre part of the jib as shown above. Fit the assembly to the crane base provided in the kit parts. Etched parts 100 provide crane jib rigging cables of varying lengths that can be fitted if it is desired to fix the crane at a certain position or angle.

SEAPLANE CATAPULT ASSEMBLY

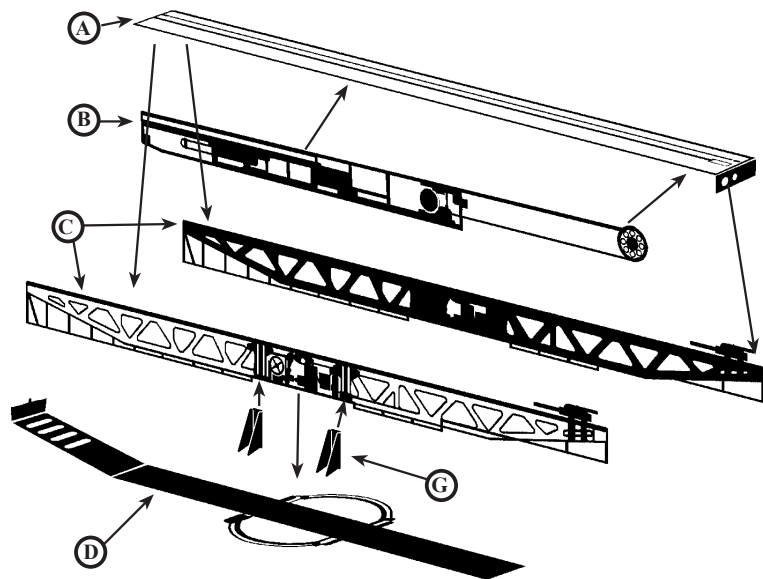
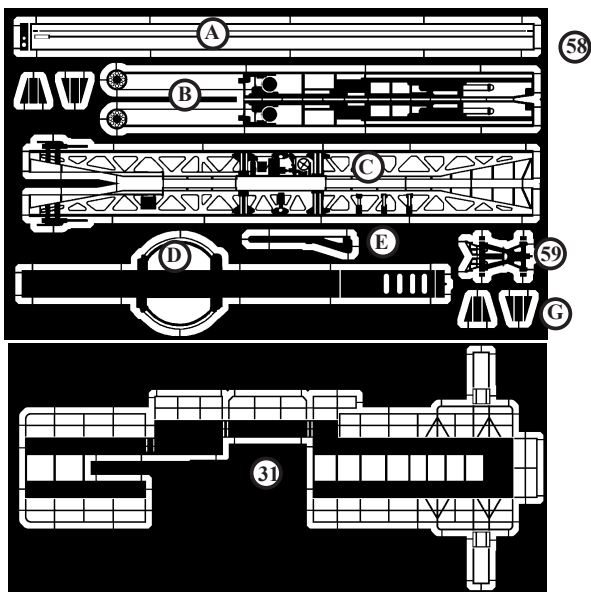

Shape the base plate 58D as shown above & fit the two side panels 58C so that the relief-etched detail is outermost. Fit the top plate 58A so that the edges attach to the top edges of 58C.

Fold the side support brackets 58G to shape & fit to the sides at the locations shown on both sides.

Fit the large compressed air discharge pipe, 58E, to the left side of the catapult on the three vertical attachment points as shown below.

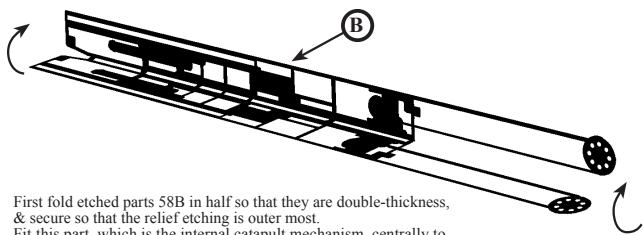

First fold etched parts 58B in half so that they are double-thickness, & secure so that the relief etching is outer most.

Fit this part, which is the internal catapult mechanism, centrally to the underside of the top plate, 58A, so that the forward pulley wheel protrudes through the slot in the plate.

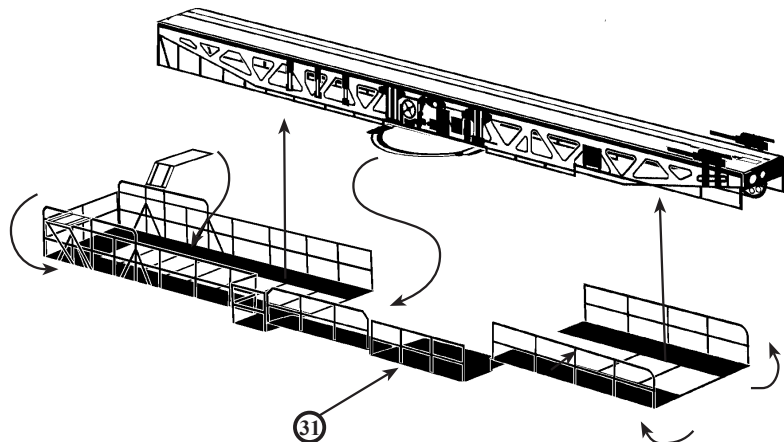
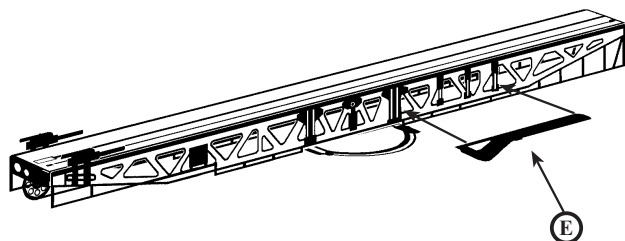

Fold the railings on the walkways, etched parts 31, up to 90°, then shape the steps on the centre walkway to 90° on each of the three steps. The narrow walkway step plates fold downwards. The wide walkway step plate folds upwards.

Fit the walkways to the frames on the lower edges of the catapult sides as shown left. Fit the centre walkway section so that the narrow raised section fits over the catapult turntable plate.

This assembly can be used to replace kit parts D6, E88 and E89. Trumpeter kit parts shown in assembly section 20 can be replaced with these items if it is wished.

There are two catapult assemblies provided in this set so that the kit can be built in the ship's pre-1945 configuration if desired.

CURTISS SOC SEAGULL DETAILS

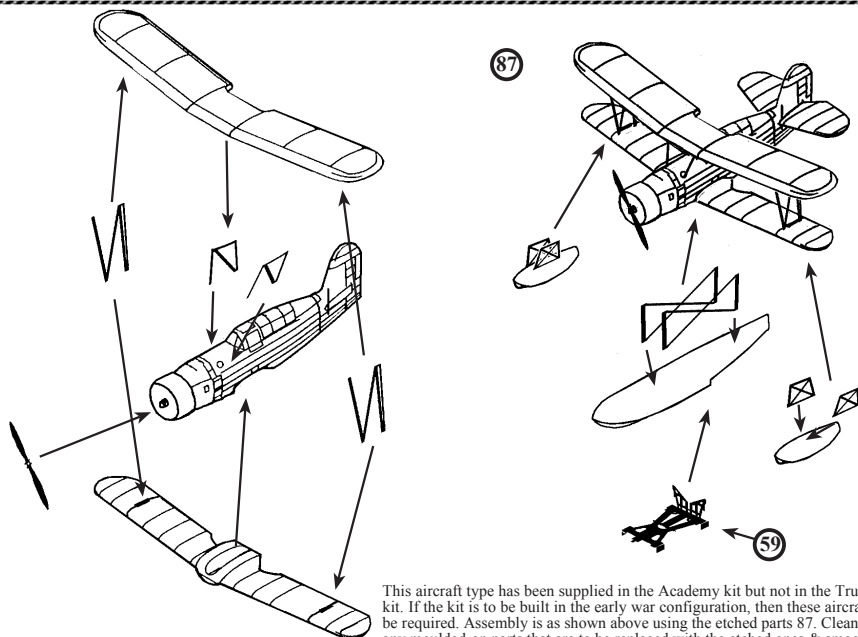

This aircraft type has been supplied in the Academy kit but not in the Trumpeter kit. If the kit is to be built in the early war configuration, then these aircraft will be required. Assembly is as shown above using the etched parts 87. Clean away any moulded-on parts that are to be replaced with the etched ones & smooth the surfaces prior to fitting. Shape the catapult launch cradles, etched parts 59 as shown above & fit to the tops of the catapult. The aircraft may be placed on top.

CURTISS SC-1 SEAHAWK

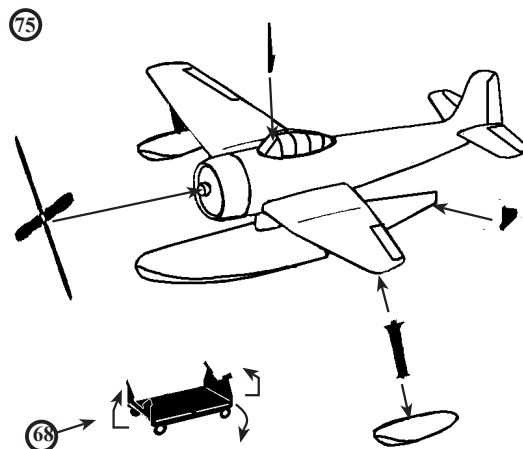

Assemble the SC-1 Seahawk floatplane as shown above, using the replacement wing float struts if desired.

The aircraft will fit into position on the catapults by fitting the large centre float into the launch cradle, etched part 59.

Alternatively, the aircraft may be stowed on deck or in the hangar, in which case they would be placed on a deck handling trolley. Shape etched parts 68 as shown above to provide two deck handling trolleys.

EARLY BOAT CRANE

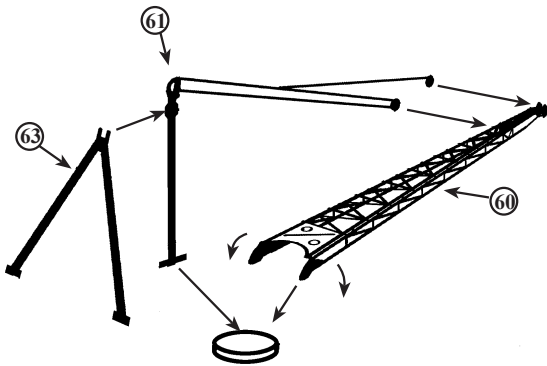

If it is wished that the kit be assembled to an earlier fit, help is provided in the form of the aft boat crane assembly. This crane was fitted onto the aft superstructure in 1942, before the large mainmast was fitted in the 1943 refit. Further research will be required to backdate the model to 1942 as there are several other differences to address--this crane being the most delicate of them.

SKY LOOKOUT ASSEMBLY

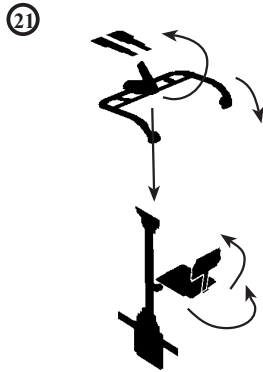

Fold the seat on the upright stand to shape as shown right. Fit the counterbalance arms to the top of the stand. Fold the binocular sights over so that they are pointing as shown above. These sky lookouts were fitted on top of the bridge decks & air defence platforms both forward & aft positions.

FLOATER NET BASKETS

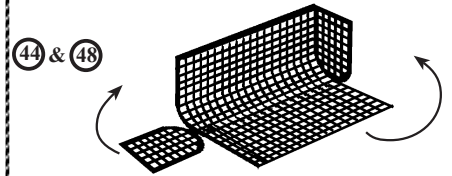

To assemble the floater net baskets, etched parts 44 & 48, gently roll the centre of the basket lengthwise into a curve until the two sides are parallel. Fold up the end panels to fit as shown above.

The shallower baskets were normally fitted to catwalk railings & bulwarks, & the larger ones to the rear of the turrets & sides of the lower mast towers. These replace kit parts E11 and E13. (PE1)

MK 8 FIRE CONTROL RADAR

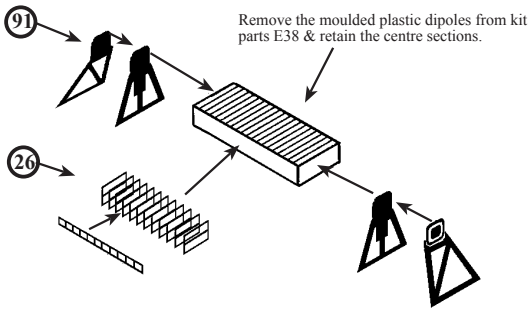

Remove the moulded plastic dipoles from kit parts E38 & retain the centre sections.

Remove the moulded plastic mounting feet on kit parts E84 and E85, & replace with the etched parts 91 as shown above. Measure the length of the dipole front spacer frame & mark the distance centrally on the front of the modified section of kit part E38. Assemble the dipoles, etched parts 26, onto the spacer frame, then fit the completed item onto the marked-out area. Make two of these items. For the Trumpeter kit, refer to section 11 in the kit instructions as the kit PE parts may be used if desired.

MK 8 FIRE CONTROL RADAR LOCATION

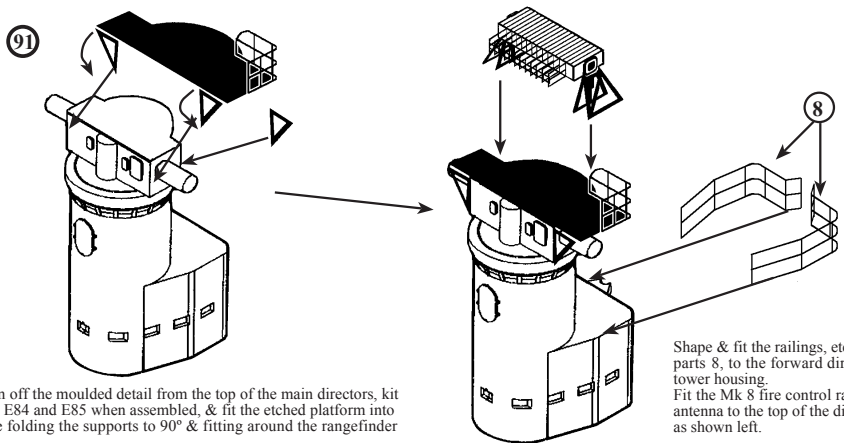

Clean off the moulded detail from the top of the main directors, kit parts E84 and E85 when assembled, & fit the etched platform into place folding the supports to 90° & fitting around the rangefinder arms.

Shape & fit the railings, etched parts 8, to the forward director tower housing. Fit the Mk 8 fire control radar antenna to the top of the director as shown left.

20MM SINGLE OERLIKON

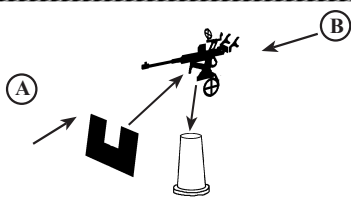

Assemble the 20mm Oerlikon as shown above. A solid pintle may be made from a length of plastic rod if desired & the etched metal one removed. Twist the shoulder braces & training wheel to the shape shown above. Turn the gunsight ring through 90°.

These gun mounts were used in various places on earlier fits, pre-1944.

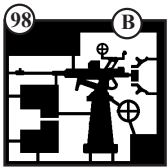

20MM TWIN OERLIKON

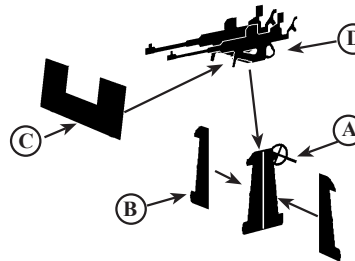

Assemble gun pintle by fitting the two half sections to each side as shown above. Kit parts may also be used. Fold up the guns to 90° so that they are parallel & fit to the top of the pintle. Fit the gun shield to the lugs below the gun bodies.

These assemblies can be used to replace kit parts G5 (E27) and G7 (PE2).



40MM QUAD BOFORS FITTINGS

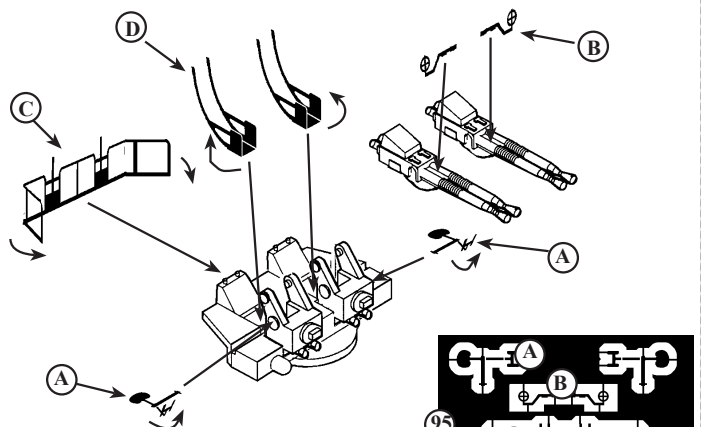

Assemble the etched parts 95 around the kit parts G2, E21, E39 & E40 as shown above. (E10, E12, E16 & E17). Remove any moulded detail, such as the gun layers' seats, that is not required, before assembly.

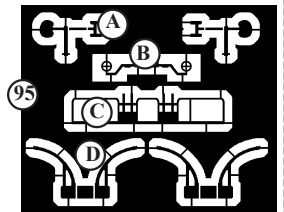

GUNNERY DIRECTOR TOWER SUPPORTS

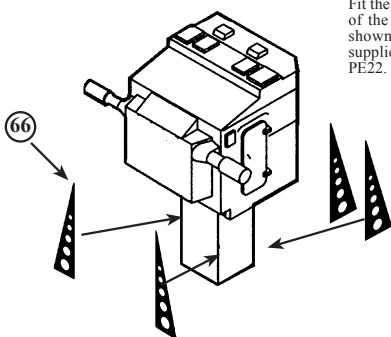

Fit the director tower supports to the base of the Mk 37 director, kit part C13, as shown below. These etched parts are supplied in the Trumpeter kit, PE 3 & PE22.

FOREMAST DIRECTOR PLATFORM SUPPORTS

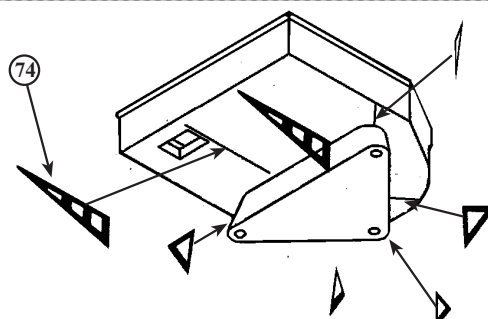

Fit the angled supports, etched parts 74, to the underside of the forward director platform, kit part C23 (A2). Some moulded parts have already been included, but should be removed before fitting the etched parts. Note: the smallest single angled bracket fits to the front of the platform.

FOREMAST DETAIL ASSEMBLY

Fold etched part 65 in half so that the open framework is on the underside. This may be used to directly replace kit part D38 (C23). Remove the moulded supports from kit part D3 & replace them with etched parts 23 & the angle supports from etched part 65.

Remove the moulded top detail from kit part D20 (C45) & fit etched parts 19 to the top & bottom of the yardarms. Fit the yardarm as per kit instructions so that the spar sits on top of the platform.

Remove the moulded detail from the mast top pole, kit part D8 & replace with etched parts 52 as shown left.

Fit the top pole to the aft locating hole on the mast platform. Fit either the SC radar antenna or the TDY antenna to the front of the mast platform.

MAINMAST DETAIL ASSEMBLY

Fold etched part 79 in half so that the open framework is underneath. Secure into place. Use this assembly to replace kit part D40 (B24). Fit the support frames, etched parts 80 and 81 to the etched lines on the underside of the platform.

Construct a replacement mast top pole using kit part D7(C30) as a base. Remove the moulded detail so that you are left with a plain pole. Fit the circular platform, etched part 52, in place of the corresponding moulded plastic platform. Fit the top array and platform, etched part 76 as shown left, then add the DF antenna 77, to the vertical pole. An SG antenna, etched part 18, may also be fitted to the mounting shown left.

During the later war years a triangular platform was fitted below the mast head. Fit the inner section of the platform, etched part 62, to the second from top horizontal bar on the rear frame of the mainmast, kit part D25. Fit the front part of the mast, kit part D24, so that the front pole locates into the recess in the front of the platform, after first folding the side railings up to 90°, & feeding them through the gap in the cross bracings as the two parts of the mast are joined. Fit the front part of the platform so that it fits over the relief-etched lip on the main part of the platform. Fold the front section of railing bracing to 90° & secure in between the first verticals of the side railings.

The Trumpeter kit already includes this platform assembly, but this one can be used to replace such items as the railings if desired.

BRIDGE FITTINGS LOCATION & ASSEMBLY

Shape and fit the bridge windows, etched part 6, to the rim of the bridge bulwark as shown below.

Remove the moulded plastic venturi detail from the front of the bridge & smooth the surface. Replace by shaping the venturi panel to fit around the bridge front as shown left, then fitting the support brackets into the relief-etched slots on the inside of the panel.

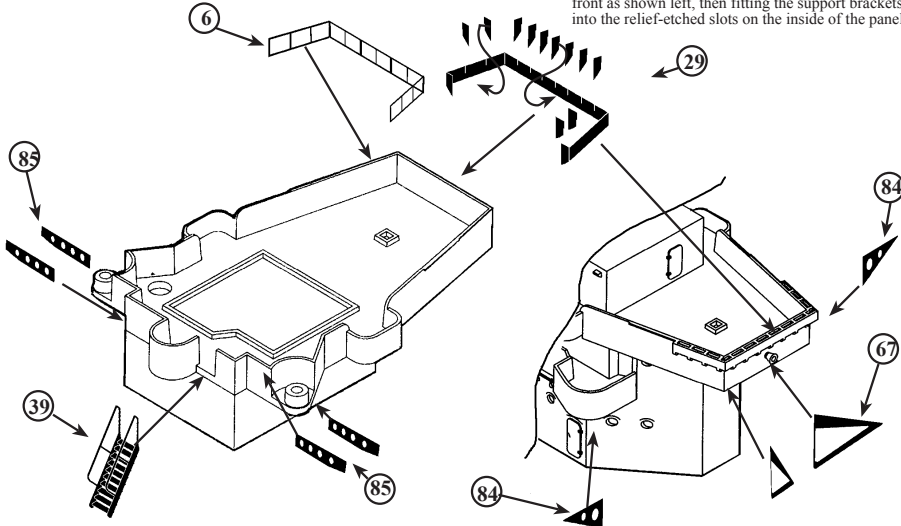

Remove any moulded detail from below the AA director tub locations & fit the support brackets, etched parts 85, into place. Shape & fit the inclined ladder, etched part 39 in to the place of kit part E10 (C37)

Remove any moulded detail from underneath the bridge front, then fit the bridge front supports, etched parts 67, into place. Fit the small supports, etched parts 84, to the underside of the lower signal light tubs

FUNNEL CAP GRILLES & CATWALKS

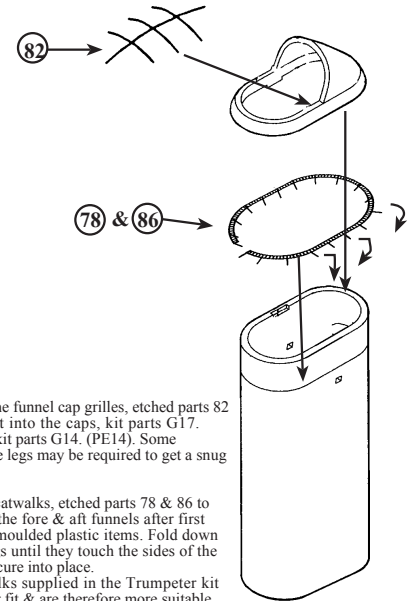

Gently curve the funnel cap grilles, etched parts 82 so that they fit into the caps, kit parts G17. These replace kit parts G14. (PE14). Some trimming of the legs may be required to get a snug fit.

Fit the funnel catwalks, etched parts 78 & 86 to the outside of the fore & aft funnels after first removing the moulded plastic items. Fold down the support legs until they touch the sides of the funnel, then secure into place. The PE catwalks supplied in the Trumpeter kit may be a better fit & are therefore more suitable for fitting to that kit.

CATAPULT DECK RAILINGS & LADDERS

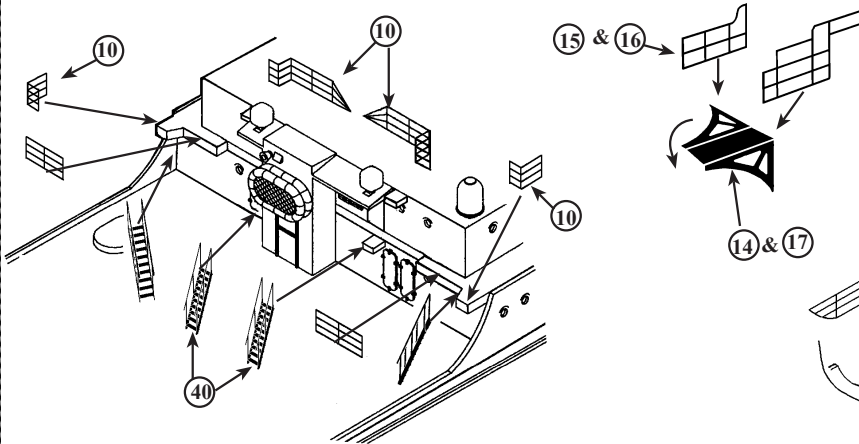

Fold down the support brackets on the catapult access platforms, etched parts 14 & 17, to 90° so that they are parallel. Fit the railings 15 & 16 as shown, then fit the platforms to the outer pillars of the hangar so that they angle inwards. The railing extension piece fits on top of the hangar roof side bulwark.

Shape & fit railing sections, etched parts 10, to the ladder landings as shown above, allowing enough clearance in between for the ladders to access. The larger railing section with the angled sections that are toed down to the middle, fit along the rear edge of the deck with a gap between the angles for the crane jib to rest.

AFT GUN DECK FITTINGS

Fit the two support cross braces, etched parts 89, to the underside of the aft main director platform as shown below.

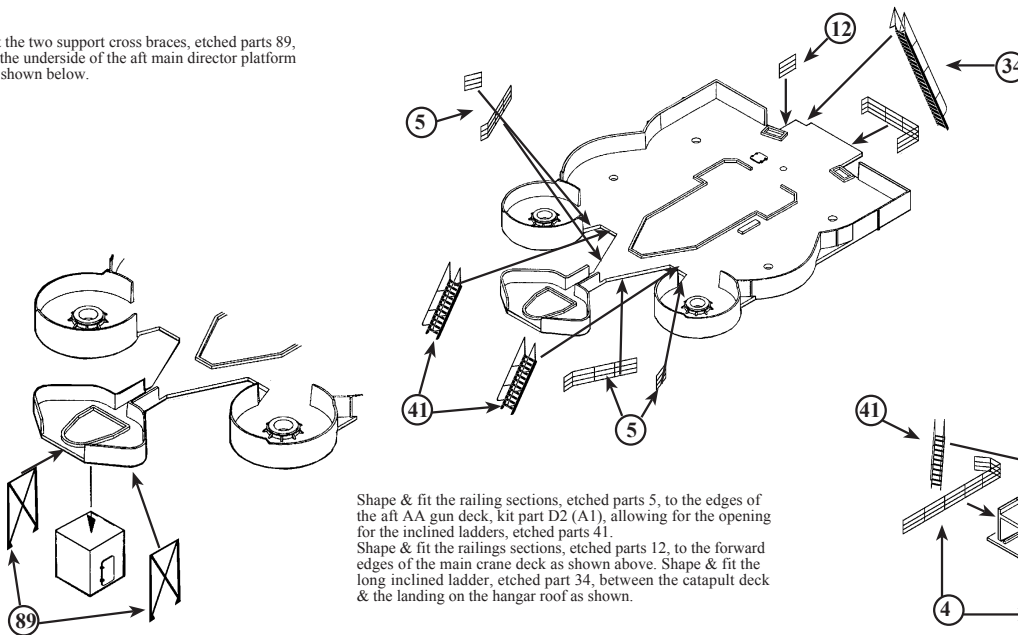

Shape & fit the railing sections, etched parts 5, to the edges of the aft AA gun deck, kit part D2 (A1), allowing for the opening for the inclined ladders, etched parts 41. Shape & fit the railings sections, etched parts 12, to the forward edges of the main crane deck as shown above. Shape & fit the long inclined ladder, etched part 34, between the catapult deck & the landing on the hangar roof as shown.

Shape & fit the railing sections, etched parts 4, to the edges of the aft 5° gun deck as shown, so that there is a ladder access gap between the railings & the gun tub splinter shield. Fit the railing sections after the deck parts have been installed in the hull & superstructure, to ensure correct fitting.

PROPELLER GUARD ASSEMBLY

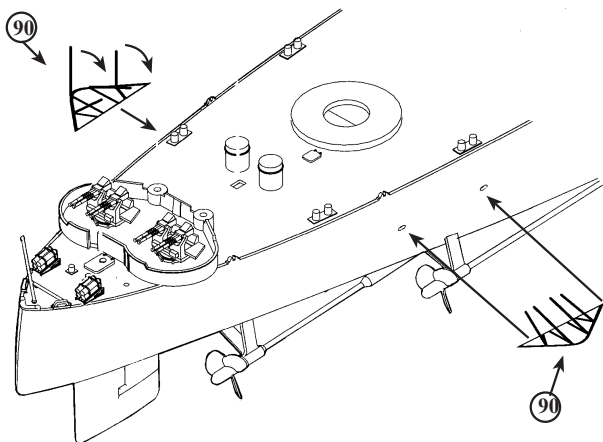

Fold the support legs on the propeller guards, etched parts 90, over to an acute angle. Fit the propeller guard frame to the sides of the hull in place of kit parts D16 & D17 (A23 & A25) using the locating holes as a guide. These holes will need to be filled & blended in after the etched propeller guards have been fitted. Attach the support legs to the ship's side so that the propeller guard frame is horizontal.

FANTAIL RAILINGS

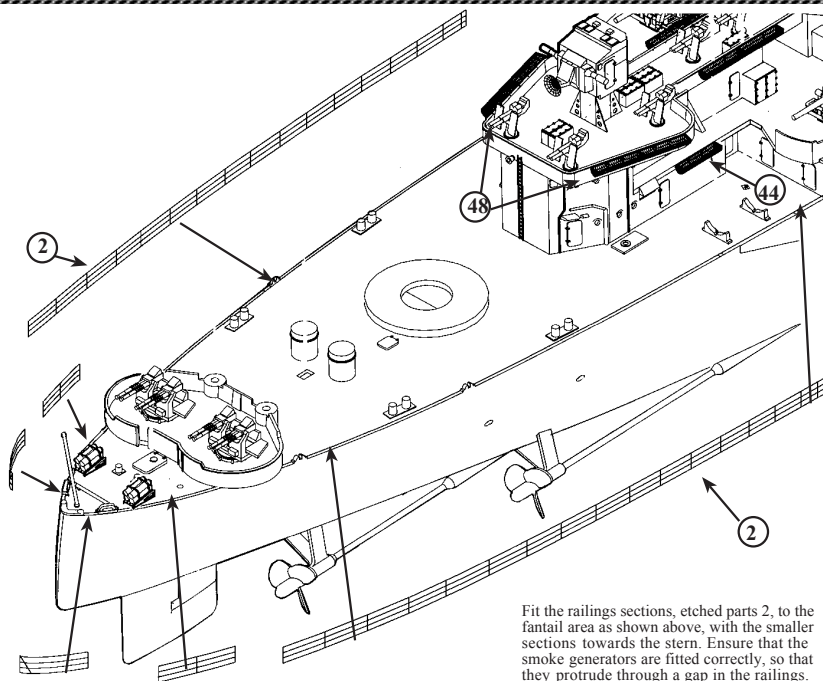

Fit the railings sections, etched parts 2, to the fantail area as shown above, with the smaller sections towards the stern. Ensure that the smoke generators are fitted correctly, so that they protrude through a gap in the railings.

ACCOMMODATION LADDER ASSEMBLY

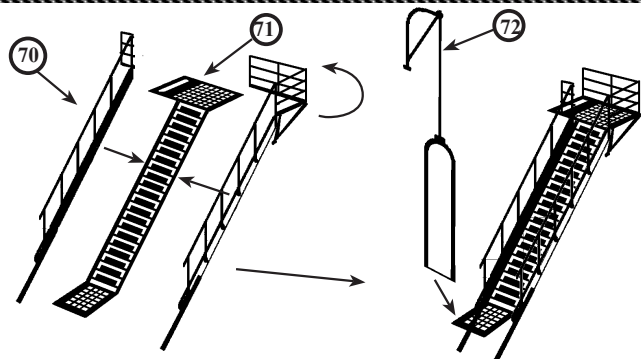

If the ship is to be modelled at anchor, accommodation ladders would normally be deployed for the ship's boats to berth alongside. Assemble the ladder set as shown above left. One port- & one starboard-fitting ladder has been provided. The correct location of the ladders appears to be that they were deployed from the catapult deck area amidships, so a gap in the railings at that location would be required at the point of attachment.

SMALL SUPERSTRUCTURE FITTINGS

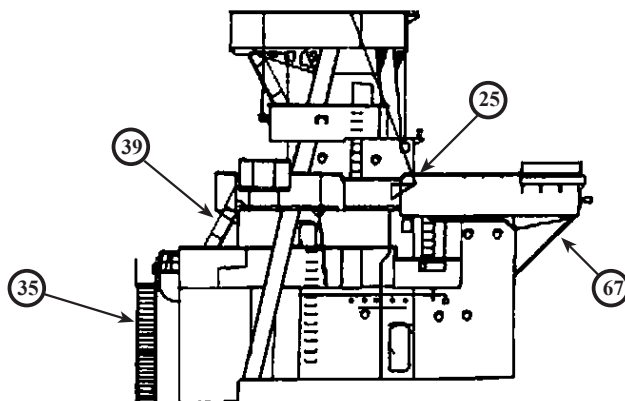

OTHER INSTRUCTIONS

- The railing sections in this set are provided as tailored-to-fit the various areas of decks & platforms as stated in the parts list. The foc'sle railing, etched part 1, is one long section that runs from the jackstaff right back to the hull step. Any differences in length between the kits that affects the fit of the railings can be taken up by inserting or replacing small sections of railing from those provided as etched parts 57.
- Life raft bases, etched parts 53 and 102, have been supplied to replace the moulded plastic bases on the kit parts E5 to E8 (D6, D8, E23 & E24). The rectangular or oval etched parts fitting to the appropriately-shaped life raft, after first removing the plastic base from the kit parts. Retaining straps for the life rafts, etched parts 54, have been provided to fit across life rafts fitted to vertical surfaces. Paddles for the life rafts, etched parts 32, may be placed inside the rafts as an additional detail.
- Stock lengths of vertical ladder, etched parts 56, have been supplied that can be cut to the length required for fitting to masts or platforms where necessary.
- Replacement hangar doors, etched parts 83, have been supplied with the intention that they may be folded, concertina fashion, into the open or partially-open state for displaying the aircraft stowed inside the hangar or being moved on deck. These large doors also have separate personnel access doors that can be displayed in the open position if desired.
- Etched parts 88 are the patterned top plates for the main anchor chain capstans, kit parts E43 (D35) which have been left plain in the kit. Simply attach to the top of the capstan with the relief detail uppermost.
- Etched parts 25 are angled brackets to secure the ends of wire antennas that are fed from the foremast yardarms. For the location of these items see the last diagram above.
- Ammunition clip racks for the 40mm Bofors gun tubs have been supplied, etched parts 92, 93 and 94. These are shaped to fit inside their respective gun tubs stated in the parts list, two per tub, one above the other.
- TBS antennas, etched parts 33, have been supplied for fitting to the mast yardarms if required. The exact number and location of these antennas will require further research as it is unclear at what stage these were fitted & in what locations.
- Stock lengths of handrail, etched parts 55, have been supplied for additional detailing. These are fitted around the sides of bulkheads & tops of low bulwarks as desired.
- Sufficient lengths of anchor chain, etched parts 101, have been provided to allow one or both anchors to be deployed if the ship is to be modelled at anchor in a diorama setting.
- References are available in the form of *Profile Morskie Plans No.14* which give a very good overview of the layout & location of the various details. Also there is a very good reference in the *Warship Pictorial No.1, USS Indianapolis CA-35* by Steve Wiper.

